

# Medical Analytical

MINIATURE  
SOLENOID VALVES

**ASCO**  
SCIENTIFIC®

# Medical

Medical equipment designed and used for preventive, diagnostic and therapeutic purposes employs many different technologies. Efficient control of the gaseous and liquid fluids contributes to equipment performance, treatment quality and comfort of the patient.

## Multi-function modules:

- solenoid valves (shut-off and/or proportional), pressure sensors, etc.
- special connections and manifold / subbase mounting
- optimised performance

ASCO/JOUCOMATIC incorporates these and other requirements in the development of dedicated products.

### • Reliability

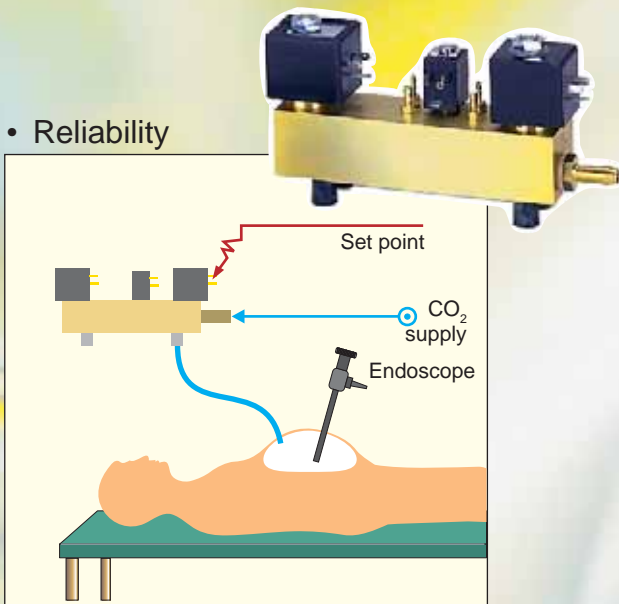

CO<sub>2</sub> feed regulation

### • Full compatibility with your fluids



Respirator

### • Miniaturisation



Dentist's chair

### • Low electric power consumption



Medical instrument steriliser

### • Ultra-pure applications



Dialysis

# Analytical

## BIOMEDICAL ANALYSES

More than any other health care domain, medical biology represents a leading edge sector in a state of constant mutation and is frequently the starting point for therapeutic innovation. The development of new methods and materials meets the demands of the practitioner in terms of test diversity, while ensuring the reliability and rapid acquisition of result data and effective cost control. Automation and miniaturisation are steadily taking over in the five principal biomedical domains of haematology, biochemistry, immunology, immunochemistry and microbiology.



Haematological analyser

Rocker type solenoid valves

Pinch type solenoid valve for ultra-pure fluids

Automatic analyser

## INDUSTRIAL APPLICATIONS

Numerous sectors (agro-business, energy, environment, chemicals, pharmaceuticals, cosmetics, etc.) use industrial analysis equipment for process control, measurement, detection, regulation, metering and other applications.



Physiochemical analyses

Bellows solenoid valve

Air analyser

**ASCO**  
SCIENTIFIC®

# 5 Fluid Isolation

Many applications require total absence of contact between the fluid (liquid or gas) and the internal parts of the solenoid valve (control system) to:

- ensure total prevention of contamination from particles of material from moving parts,
- minimise heat transfer from the electromagnetic part, and
- ensure a high level of reliability for the solenoid valve for handling extremely aggressive fluids.

Through their specific characteristics and performance, the five fluid isolation technologies used in our range of solenoid valves provide relevant solutions to address your application requirements.

## DIAPHRAGM

- Low electric power consumption
- Small dead volume
- Quick response time

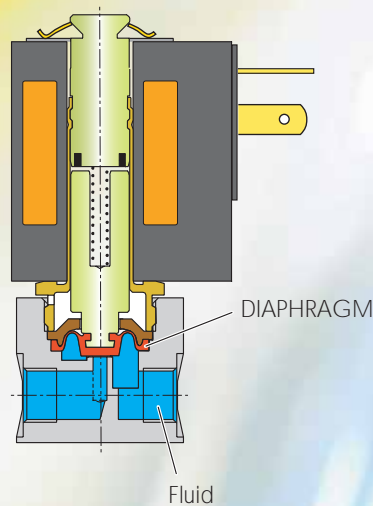

## ROCKER

- Miniature solenoid valve
- Small dead volume
- Laboratory or industrial type connections
- Suitable for mounting in series

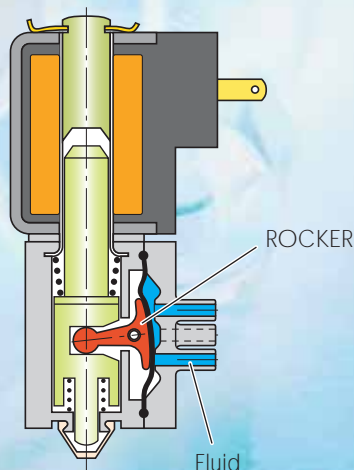

# Technologies

## LEVER

- High flow rate
- Laboratory or industrial type connections
- Easy to disassemble
- Minimum heat transfer to fluids

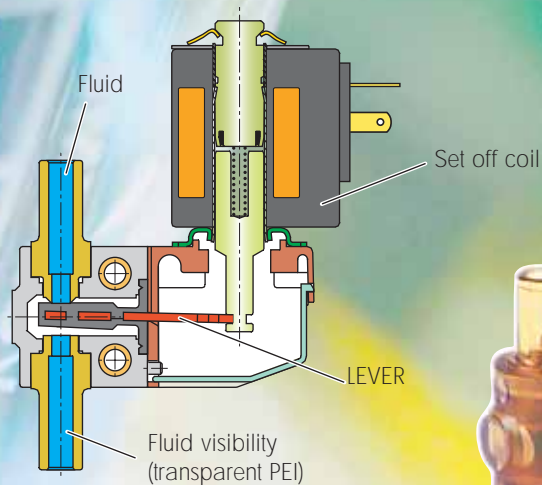

## TUBE PINCH

- Miniature solenoid valve
- Ultra-pure fluids
- Low electric power consumption
- Suitable for mounting in series

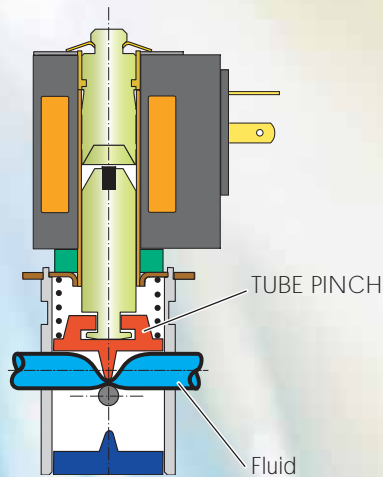

## BELLOWS

- Highly aggressive fluids
- Industrial type connections

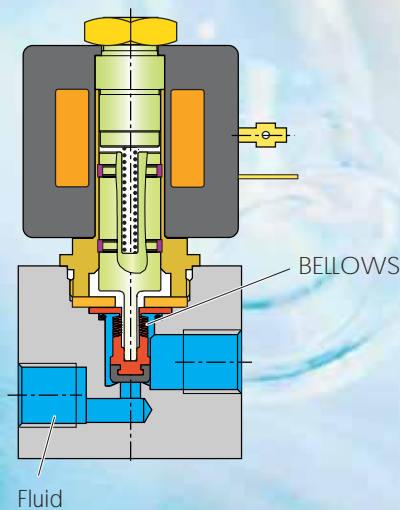

**ASCO**  
SCIENTIFIC®

# New Products

## New fluid isolation solenoid valves:

- ensure total prevention of contamination
- minimise heat transfer
- ensure a high level of reliability for handling extremely aggressive fluids

## ROCKER

(series 067, page X006-01-05)

- Miniature solenoid valve
- Power saving
- Very low dead volume
- Electrical connection for plug-type connector or with flying leads
- Pad mounting body
- Self-draining capability
- Easy installation

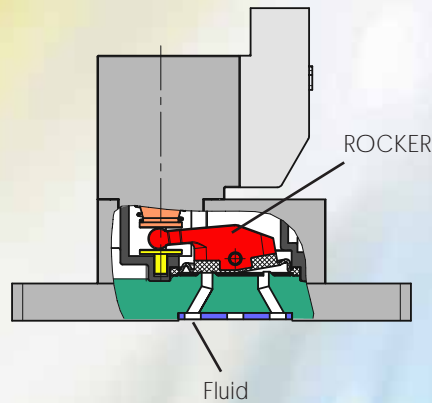

## ROCKER

(series 385, page X006-01-25)

- New version with polyamide body
- Very low dead volume
- Easy-to-flush internal cavity
- Low heat transfer, suitable for series mounting

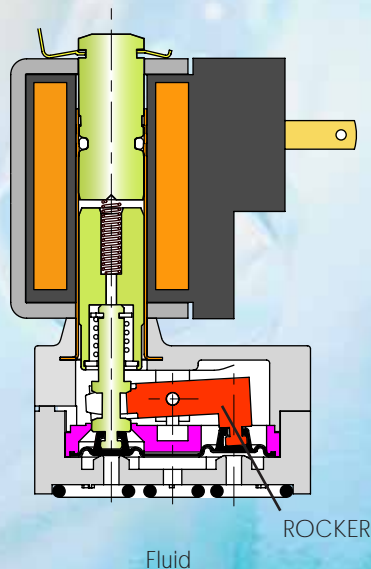

# New Products

Among the new products available for an even wider range of applications we can offer:

- Flat-spring technology ideal for the control of fluids requiring extremely short response times
- Proportional PRECIFLOW solenoid valves for high-precision flow control

Through their specific characteristics and performance, both fluid isolation technologies used in our range of solenoid valves provide relevant solutions to address your application requirements.

## FLAT SPRING

(series 065, pages X006-03-05 and X006-03-10)

- No fluid contamination
- Extremely short response times
- Long service life: 1 billion cycles
- Easy to install in confined spaces

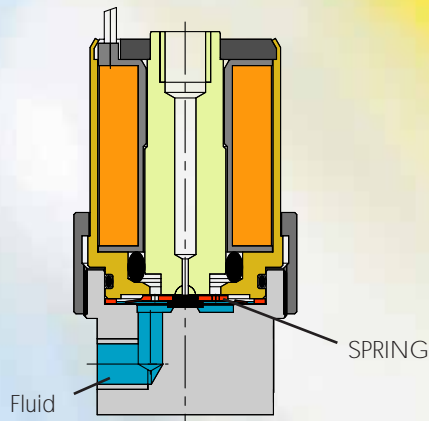

## PRECIFLOW

(series 202, page X006-04-07)

- Very low hysteresis
- Dynamic flow control
- Variety of connection possibilities:
  - M5 or G 1/8 thread
  - Pad-mount according to ISO 15218 (CNOMO, size 15)

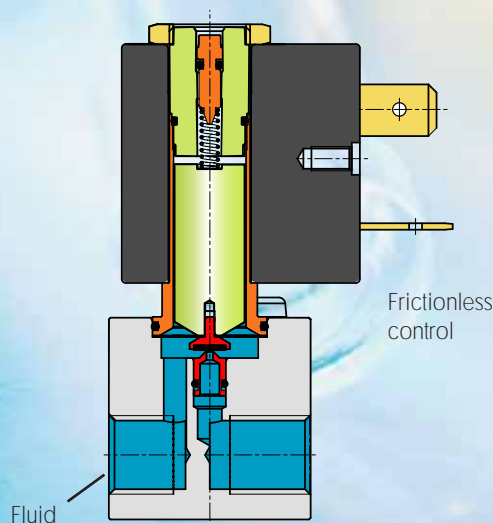

# ASCO SCIENTIFIC®

ASCO SCIENTIFIC is the brand name under which ASCO/JOUCOMATIC, a world leader in the solenoid valve field, markets five fluid isolation product ranges for the **medical, biomedical and industrial analysis markets**.

Where standard products no longer provide the answer, our wealth of expertise and experience enables us to design and develop dedicated solenoid valves and multi-function modules to meet your particular needs.

The ASCO SCIENTIFIC catalogue of miniature solenoid valves includes these ranges together with a selection of components (shut-off and proportional solenoid valves, etc.) from the ASCO/JOUCOMATIC comprehensive range, and presents a global, personalised product package matching your **particular requirements**.

All our products – valves, solenoid valves and pneumatic components and fittings – are on show at : [www.ascojoucomatic.com](http://www.ascojoucomatic.com).

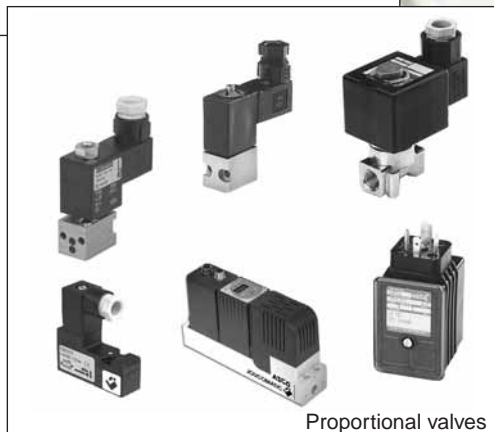

# S U M M A R Y

## Isolation valves

Series 067 - 2/2-3/2, rocker, pad mounting - 1/8	X006-01-05 / 07
Series 110 - 2/2-3/2, rocker, hose connections	X006-01-10
Series 360 - 3/2, rocker, threaded connections	X006-01-15
Series 360 - 2/2-3/2, rocker, pad mounting	X006-01-20
Series 385 - 3/2, rocker, pad mounting	X006-01-25
Series 282 - 2/2, diaphragm, cartridge, Ø 8 mm	X006-01-28
Series 282 - 2/2, diaphragm, M5 - 1/8 - 1/4	X006-01-30 / 35
Series 283/383 - 2/2 3/2, lever, smooth spigots, Ø ext. 8 - 11mm	X006-01-40 / 50
Series 283/383 - 2/2 3/2, lever, threaded connection, 1/4 - 1/2	X006-01-45 / 55
Series 296 - 2/2, bellows, 1/4 - 3/8	X006-01-65
Series 396 - 3/2, bellows, 1/4	X006-01-70

## Pinch valves

Series 284 - 2/2, NC	X006-02-05
Series 284 - 2/2, NO	X006-02-05-3
Series 384 - 3/2, U	X006-02-05-5

## Non isolation valves

Series 065 - 2/2, threaded or pad-mount body	X006-03-05
Series 065 - 3/2, threaded or pad-mount body	X006-03-10
Series 108 - 2/2, pad mounting	X006-03-15
Series 109 - 3/2, pad mounting	X006-03-20
Series 188 - 3/2, micro 10 range	X006-03-25
Series 188 - 3/2, micro 10 LF range	X006-03-27
Series 302 - 2/2, pad mounting	X006-03-30
Series 302 - 3/2, pad mounting	X006-03-35

## Proportional valves

Series 630 - 2/2, Piezotronic	X006-04-05
Series 202 - 2/2, threaded M5, 1/8 - pad mounting (Preciflow)	X006-04-08
Series 202 - 2/2, pad mounting	X006-04-10
Series 202 - 2/2, 1/8 threaded	X006-04-16
Series 202 - 2/2, 1/4 - 3/8 threaded	X006-04-20
Series 908 - Electronic proportional control unit	X006-04-30
Series 603 - Control <sup>D</sup> controller module	X006-04-35
Series 607 - Proportional valves Flowtronic <sup>D</sup> , 1/4	X006-04-45

## Accessories

Connectors	X006-05-05
------------	------------

## Specialised products

Multi-function modules	X006-06-05
Solenoid valves	X006-06-05-2

## General information

Solenoid valve terminology	X006-07-05
Definitions	X006-07-05-2
Rubbers, plastics and metals	X006-07-15
Chemical resistance guide	X006-07-20
Conversion tables	X006-07-25

1

2

3

4

5

6

7

