

FEATURES

- Top loading (double) types are designed for the connection (coupling) of different blow tubes
- The bottom loading (single) type is suitable for one-piece blow tube for dust collector service
- Quick and economical installation because there is no need for welding or threaded pipe connections
- Less sensitive to blow tube misalignments in the system
- Enables a modular filter system design

GENERAL

Differential pressure 0 - 8,5 bar [1 bar = 100 kPa]
Safe static pressure (PS) 8,5 bar
Ambient temperature range -20 to +85°C

fluids	temperature range (TS)	sealings
air	-20 to +85°C	NBR (nitrile)

CONSTRUCTION

Body Aluminium
Gasket Klingerit
Nut retainer Aluminium
Nut compression Aluminium
Retainer seal Steel (zinc plated)
Seal NBR (nitrile)

SPECIFICATIONS

pipe size	for blow tube		catalogue number
	Ø external (mm)	Ø internal (mm)	
Bottom loading (single) bulkhead connector			
3/4	26,4	19	BF20S
1	33,2	25	BF25S
1 1/2	47,8	38	BF40S
Top loading (double) bulkhead connector			
3/4	26,4	19	BF20D
1	33,2	25	BF25D
1 1/2	47,8	38	BF40D

INSTALLATION

- The compression fitting tightness is achieved by the compressed gasket on the blow tube
- Installation/maintenance instructions are included with each bulkhead connector

DIMENSIONS (mm), WEIGHT (kg)



catalogue number	A	B	C	D	E	F	weight	(C)
BF20S	63	48	12	12	73	-	0,30	Fig. 1
BF25S	76	55	12	12	72	-	0,43	
BF40S	98	73	15	15	92	-	0,78	
BF20D	63	48	12	12	61	116	0,48	Fig. 2
BF25D	76	55	12	12	60	118	0,69	
BF40D	98	73	15	15	77	144	1,20	

(C) construction type

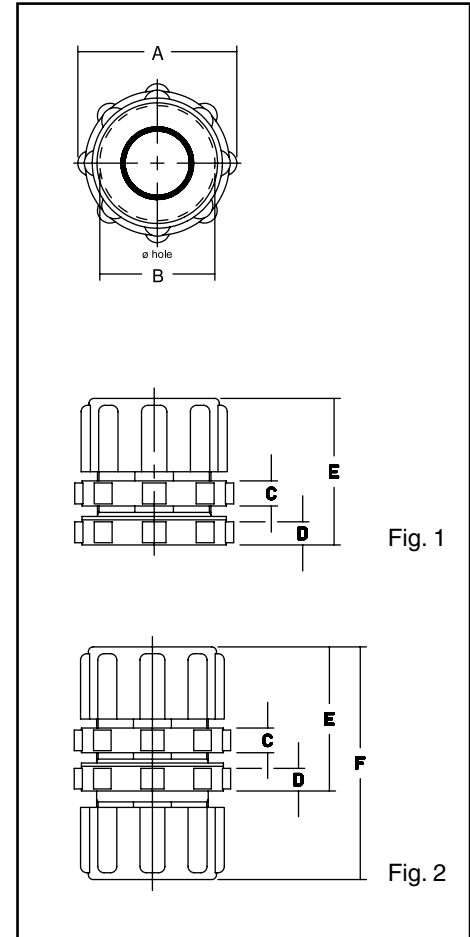
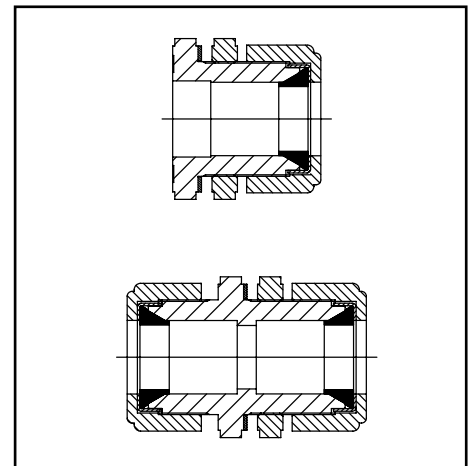

Fig. 1

Fig. 2