

GENERAL

Detection
Fluid
Operating pressure
Ambient temperature
Optimal max. speed
Max. speed rate
Standards

Equipped for magnetic position detectors
Air or neutral gas, filtered, lubricated or not
10 bar max.
-20°C, to +70°C (for higher t°, see page P239)
≤ 1 m/s (for optimal service life)
2 m/s
ISO 15552-AFNOR NF ISO 15552-DIN ISO 15552
(replace ISO 6431-AFNOR NFE 49003-VDMA 24562)

CONSTRUCTION

Barrel
Tie rods
Rod
Piston

Piston seal
Front and rear ends
Bearing
Cushioning

Hard anodized aluminium alloy
Stainless steel (Ø 32-100), paint steel (Ø 125-200)
Hard chrome plated steel with rod nut galvanized steel
Ø32 to 80 mm: POM (polyacetal), Ø100-125 mm: light alloy
fitted with an annular permanent magnet
PUR (polyurethane)
Aluminium alloy
Metal self lubricating
Pneumatic, adjustable from both sides with captive screws



B

CHOICE OF EQUIPMENT

Ø (mm)	stroke (mm) (1)	catalogue number (2)	reference	connec-tion Ø	cushioning length (mm)
32 (3)	25	45000710	PES 32 T A 25 R-DM	G 1/8	18
	50	45000711	PES 32 T A 50 R-DM		
	80	45001095	PES 32 T A 80 R-DM		
	100	45000712	PES 32 T A 100 R-DM		
	125	45001113	PES 32 T A 125 R-DM		
	160	45000713	PES 32 T A 160 R-DM		
	200	45000714	PES 32 T A 200 R-DM		
40	25	45000716	PES 40 T A 25 R-DM	G 1/4	20
	50	45000717	PES 40 T A 50 R-DM		
	80	45001096	PES 40 T A 80 R-DM		
	100	45000718	PES 40 T A 100 R-DM		
	125	45001114	PES 40 T A 125 R-DM		
	160	45000719	PES 40 T A 160 R-DM		
	200	45000720	PES 40 T A 200 R-DM		
50	25	45000724	PES 50 T A 25 R-DM	G 1/4	26
	50	45000725	PES 50 T A 50 R-DM		
	80	45001097	PES 50 T A 80 R-DM		
	100	45000726	PES 50 T A 100 R-DM		
	125	45001115	PES 50 T A 125 R-DM		
	160	45000727	PES 50 T A 160 R-DM		
	200	45000728	PES 50 T A 200 R-DM		
63	25	45000734	PES 63 T A 25 R-DM	G 3/8	26
	50	45000735	PES 63 T A 50 R-DM		
	80	45001098	PES 63 T A 80 R-DM		
	100	45000736	PES 63 T A 100 R-DM		
	125	45001116	PES 63 T A 125 R-DM		
	160	45000737	PES 63 T A 160 R-DM		
	200	45000738	PES 63 T A 200 R-DM		
80	25	45000744	PES 80 T A 25 R-DM	G 3/8	27
	50	45000745	PES 80 T A 50 R-DM		
	80	45001099	PES 80 T A 80 R-DM		
	100	45000746	PES 80 T A 100 R-DM		
	125	45001117	PES 80 T A 125 R-DM		
	160	45000747	PES 80 T A 160 R-DM		
	200	45000748	PES 80 T A 200 R-DM		

Ø (mm)	stroke (mm) (1)	catalogue number (2)	reference	connec-tion Ø	cushioning length (mm)
100	50	45001192	PES 100 T A 50 R-DM	G 1/2	33
	80	45001193	PES 100 T A 80 R-DM		
	100	45001194	PES 100 T A 100 R-DM		
	125	45001195	PES 100 T A 125 R-DM		
	160	45001196	PES 100 T A 160 R-DM		
	200	45001197	PES 100 T A 200 R-DM		
	250	45001198	PES 100 T A 250 R-DM		
	320	45001199	PES 100 T A 320 R-DM		
	400	45001200	PES 100 T A 400 R-DM		
	500	45001201	PES 100 T A 500 R-DM		
	630	45001202	PES 100 T A 630 R-DM		
	700	45001203	PES 100 T A 700 R-DM		
	800	45001204	PES 100 T A 800 R-DM		
900	45001205	PES 100 T A 900 R-DM			
1000	45001206	PES 100 T A 1000 R-DM			
125	50	45001208	PES 125 T A 50 R-DM	G 1/2	37
	80	45001209	PES 125 T A 80 R-DM		
	100	45001210	PES 125 T A 100 R-DM		
	125	45001211	PES 125 T A 125 R-DM		
	160	45001212	PES 125 T A 160 R-DM		
	200	45001213	PES 125 T A 200 R-DM		
	250	45001214	PES 125 T A 250 R-DM		
	320	45001215	PES 125 T A 320 R-DM		
	400	45001216	PES 125 T A 400 R-DM		
	500	45001217	PES 125 T A 500 R-DM		
	630	45001218	PES 125 T A 630 R-DM		
	700	45001219	PES 125 T A 700 R-DM		
	800	45001220	PES 125 T A 800 R-DM		
900	45001221	PES 125 T A 900 R-DM			
1000	45001222	PES 125 T A 1000 R-DM			
160	50	45001223	PES 160 T A 50 R-DM	G 3/4	55
	80	45001224	PES 160 T A 80 R-DM		
	100	45001225	PES 160 T A 100 R-DM		
	125	45001226	PES 160 T A 125 R-DM		
	160	45001227	PES 160 T A 160 R-DM		
	200	45001228	PES 160 T A 200 R-DM		
	250	45001229	PES 160 T A 250 R-DM		
	320	45001230	PES 160 T A 320 R-DM		
	400	45001231	PES 160 T A 400 R-DM		
	500	45001232	PES 160 T A 500 R-DM		
	630	45001233	PES 160 T A 630 R-DM		
	700	45001234	PES 160 T A 700 R-DM		
	800	45001235	PES 160 T A 800 R-DM		
900	45001236	PES 160 T A 900 R-DM			
1000	45001237	PES 160 T A 1000 R-DM			
200	50	45001238	PES 200 T A 50 R-DM	G 3/4	55
	80	45001239	PES 200 T A 80 R-DM		
	100	45001240	PES 200 T A 100 R-DM		
	125	45001241	PES 200 T A 125 R-DM		
	160	45001242	PES 200 T A 160 R-DM		
	200	45001243	PES 200 T A 200 R-DM		
	250	45001244	PES 200 T A 250 R-DM		
	320	45001245	PES 200 T A 320 R-DM		
	400	45001246	PES 200 T A 400 R-DM		
	500	45001247	PES 200 T A 500 R-DM		
	630	45001248	PES 200 T A 630 R-DM		
	700	45001249	PES 200 T A 700 R-DM		
	800	45001250	PES 200 T A 800 R-DM		
900	45001251	PES 200 T A 900 R-DM			
1000	45001252	PES 200 T A 1000 R-DM			
250	nous consulter				

(1) Other strokes on request (to specify on order within the reference)
 (2) **The magnetic position detectors are ordered separately:**
 - "T" model (see page P291), "COMPACT" model (see page P293)
 reed switch or magneto-resistive type
 - ATEX (see page X019-315 of ATEX catalogue)
 - "BIM" model, magneto-inductive (see page P297)
 (3) In the case of use of a BIM magnetic detector on PES series 450 Ø 32, it is necessary to add the option cat no.: 995125

MOUNTINGS (see Fluid Power catalogue page P242 or ATEX catalogue page X019-312)

OPTIONS AND SPECIFIC VERSIONS

(see Fluid Power catalogue page P239)
 • High temperature version (0° C to 120° C) - see page P239

OPTIONS

- Other strokes on request
- Non cushioned (NA) version on request.
- Piston rod in 316L stainless steel, catalogue number: **995002** - in 303 stainless steel, catalogue number: **995202**
- Overlength piston rod in hard chrome steel, cat. n°: **995003** - in 316L stainless steel, cat. n°: **995004** - in 303 stainless steel, cat. n°: **995204**
- Type PES cylinders with tie-rods are available in versions for use in potentially **explosive dust or gas atmospheres** according to Directive 94/9/EC.

Classification : II3GD c - Ta 40°C T85°C (T6) - Ta 70°C T100°C (T5) (ZONE 2-22) - cat no.: **612013**
 II2GD c - Ta 40°C T85°C (T6) - Ta 70°C T100°C (T5) (ZONE 1-21) - cat no.: **612016**

- Non cushioned (NA) ATEX version available on request.

ACCESSORIES

Mounting kit for series 551 Namur valves:

- - Mounting flanges (set of 2) - cat no.: \varnothing 32 mm = **88100857** \varnothing 63 mm = **88100860**
 \varnothing 40 mm = **88100858** \varnothing 80 mm = **88100861**
 \varnothing 50 mm = **88100859** \varnothing 100 mm = **88100862**

- Namur adapter plate - cat no.: **88145360**
- Fittings and pneumatic supply tubes are not included

DIMENSIONS (mm), WEIGHT (kg)

Bare cylinder

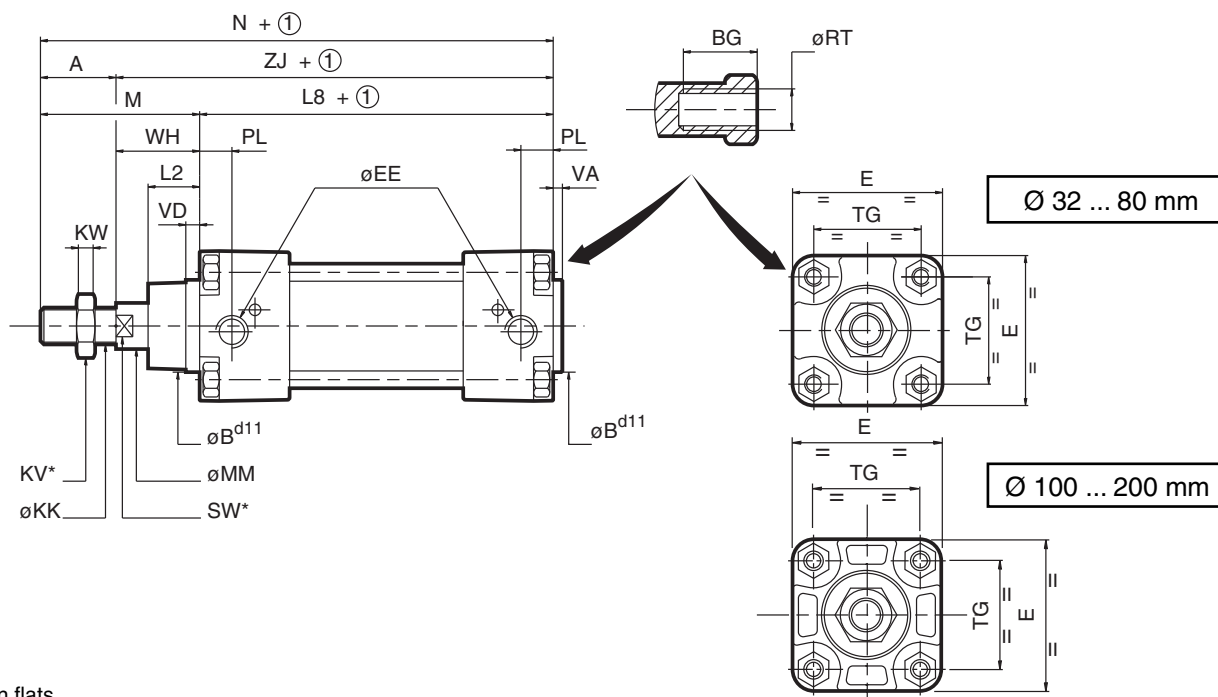

① Stroke

(*) Dimensions on flats.

Ø	A	ØB ^{d11}	BG	E	ØEE	ØKK	KV	KW	L2	L8	M	ØMM	N	PL	ØRT	SW(5)	TG	VA	VD mini
32	22	30	16	50	G1/8	M10x1,25	16	5	17	94	48	12	142	14	M6	10	32,5 ± 0,5	4	4
40	24	35	16	57,5	G1/4	M12x1,25	18	6	19	105	54	16	159	16	M6	13	38 ± 0,5	4	4
50	32	40	16	65	G1/4	M16x1,5	24	8	26	106	69	20	175	18,5	M8	17	46,5 ± 0,6	4	4
63	32	45	16	79	G3/8	M16x1,5	24	8	26	121	69	20	190	17	M8	17	56,5 ± 0,7	4	4
80	40	45	17	100	G3/8	M20x1,5	30	10	33	128	86	25	214	16,5	M10	22	72 ± 0,7	4	4
100	40	55	17	120	G1/2	M20x1,5	30	10	35,5	138	91	25	229	21	M10	22	89 ± 0,7	4	4
125	54	60	24	145	G1/2	M27x2	41	13,5	40	160	119	32	279	32	M12	27	110 ± 1,1	6	6
160	72	65	29,5	180	G3/4	M36x2	55	18	58	180	152	40	332	35,5	M16	36	140 ± 1,1	6	6
200	72	75	29,5	220	G3/4	M36x2	55	18	58	180	167	40	347	35	M16	36	175 ± 1,1	6	6

Ø	WH	ZJ	weight	
			(3)	(4)
32	26	120	0,590	0,235
40	30	135	0,840	0,335
50	37	143	1,200	0,510
63	37	158	1,500	0,540
80	46	174	2,860	0,840
100	51	189	3,675	1,185
125	65	225	6,955	1,360
160	80	260	12,835	2,100
200	95	275	17,575	2,500

- (3) Cylinder weight with 0 mm stroke.
- (4) Weight to be added per additional 100 mm length.
- (5) Dimension SW changed as against standard AFNOR NFE 49 003.

	NFE 49 003	ISO 15552
Ø 50-63	16	17
Ø 80-100	21	22

Dimensional tolerances according to standard ISO 15552