

GENERAL

Detection Equipped for magnetic position detectors
Fluid Air or neutral gas, filtered, lubricated or not
Operating pressure 10 bar max.
Ambient temperature -20°C to +70°C (for higher temperatures, consult us)
Optimal max. speed ≤ 1 m/s (for optimal service life)
Max. speed rate 2 m/s
Standards ISO 15552-AFNOR NF ISO 15552-DIN ISO 15552 (replace ISO 6431-AFNOR NFE 49003-VDMA 24562)

CONSTRUCTION

Barrel Hard anodized aluminium alloy
Front and rear ends Aluminium alloy
Barrel/end connection With stainless steel tie-rods
Bearing self-lubricating metal
Cushioning seals PUR (polyurethane)
Cushioning Pneumatic, adjustable from both sides with captive screw
Rod Hard chrome plated steel
Rod nut Galvanized steel
Piston Ø 32 to 80 mm: POM (polyacetal)
 Ø 100-125 mm: light alloy, fitted with an annular permanent magnet
Piston seals PUR (polyurethane)

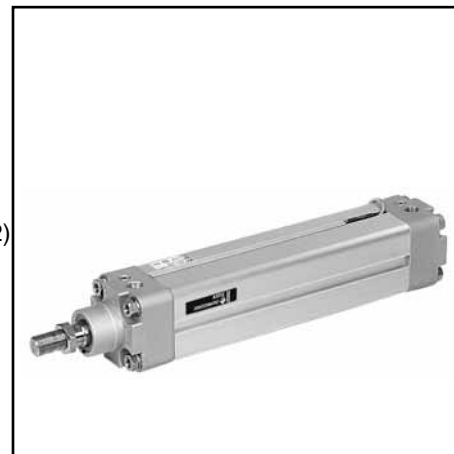

B

SPECIFICATIONS

DEFINING THE CYLINDER CATALOGUE NUMBER

Standard version: profiled barrel with adjustable pneumatic cushioning, equipped for magnetic position detectors (T-slot grooves in 12 o'clock position). Other versions available (see tables below).

To order, please specify:

■ **CYLINDER**

- The cylinder type (profiled, with or without cushioning, equipped or not for magnetic position detectors).
- The position of the T-slot groove or dovetail groove on the cylinder.
- The cylinder diameter and its stroke.

■ **DETECTORS:** The magnetic position detectors must be ordered separately :

- "T" model (see page P291), "COMPACT" model (see page P293), reed switch or magneto-resistive type
- ATEX (see page X019-315 of ATEX catalogue)

453 5

cylinder type			type	
barrel	cushioning	position detection	single rod	through rod
Profiled barrel	Cushioned	Equipped	00	0A
	Non-cushioned	Equipped	02	0C

Ø (mm)	standard stroke (mm) (1)													max. strokes (mm)			
	(recommended standard strokes) (2)																
	25	50	80	100	125	160	200	250	320	400	500	630	700	800	900	1000	
32	•	•	•	•	•	•	•	•	•	•	•	•	•	•	•	•	1000
40	•	•	•	•	•	•	•	•	•	•	•	•	•	•	•	•	1500
50-63	•	•	•	•	•	•	•	•	•	•	•	•	•	•	•	•	1800
80	•	•	•	•	•	•	•	•	•	•	•	•	•	•	•	•	2000
100	•	•	•	•	•	•	•	•	•	•	•	•	•	•	•	•	2000

groove position		type
Position of the T-slot grooves on the profiled PES cylinder	12 o'clock	0
	3 o'clock	3
	6 o'clock	6
	9 o'clock	9
Position of the dovetail grooves on the profiled PES cylinder	12 o'clock	9
	3 o'clock	0
	6 o'clock	3
	9 o'clock	6

cylinder Ø type	Ø (mm)
3	32
4	40
5	50
6	63
8	80
1	100

(1) Other strokes on request.

(2) Minimum stroke to mount 2 detectors on Ø 32 mm: 40 mm

Ordering example:

- profiled cylinder with pneumatic cushioning equipped for detectors = **00**
- T-slot grooves at 3 o'clock position = **3**
- Cylinder Ø 80 mm = **8**
- Stroke 100 mm = **0100**

Ordering catalogue number: **453500380100**

OPTIONS

- Other strokes on request
- Piston rod in 316L stainless steel, catalogue number: **995002** - in 303 stainless steel, catalogue number: **995202**
- Overlength piston rod in hard chrome steel, cat. n°: **995003** - in 316L stainless steel, cat. n°: **995004** - in 303 stainless steel, cat. n°: **995204**
- Type PES cylinders with profiled barrel are available in versions for use in potentially **explosive dust or gas atmospheres** according to Directive 94/9/EC

Classification : II3GD c - Ta 40°C T85°C (T6) - Ta 70°C T100°C (T5) (ZONE 2-22) - cat no.: **612014**

II2GD c - Ta 40°C T85°C (T6) - Ta 70°C T100°C (T5) (ZONE 1-21) - cat no.: **612017**

ACCESSORIES: • Protective groove cover and detector cable holder -see Fluid Power catalogue page P291

- Mounting kit for series 551 Namur valves:
- Fastening nut for dovetail groove (set of 2) - cat no.: **88145359**
- Namur adapter plate - cat no.: **88145360**
- Fittings and pneumatic supply tubes are not included

MOUNTINGS: see Fluid Power catalogue page P242 or ATEX catalogue page X019-312

VERSIONS: - Options and specific versions (see Fluid Power catalogue page P239)



00334GB-2009/R01 Availability, design and specifications are subject to change without notice. All rights reserved.

DIMENSIONS (mm), WEIGHT (kg) 

Bare cylinder

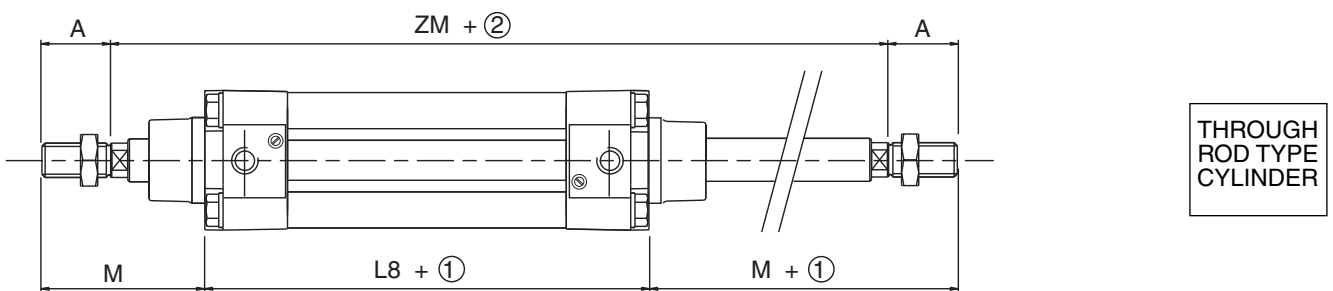
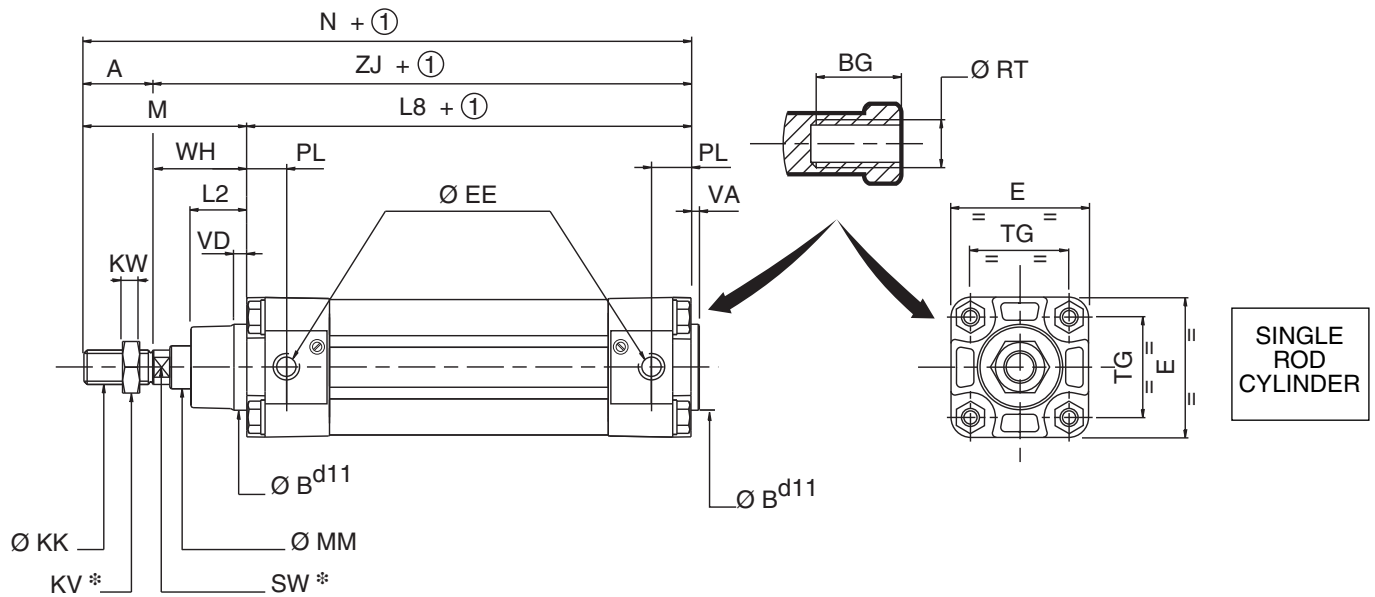

- ① Stroke
- ② Stroke x 2
- * Dimensions on flats

Ø	A	ØB ^{d11}	BG	E	ØEE	ØKK	KV	KW	L2	L8	M	ØMM	N	PL	ØRT	SW ⁽⁵⁾	TG	VA	VD _{mini}
32	22	30	16	50	G1/8	M10x1,25	16	5	17	94	48	12	142	14	M6	10	32,5 ±0,5	4	4
40	24	35	16	57,5	G1/4	M12x1,25	18	6	19	105	54	16	159	16	M6	13	38 ±0,5	4	4
50	32	40	16	65	G1/4	M16x1,5	24	8	26	106	69	20	175	18,5	M8	17	46,5 ±0,5	4	4
63	32	45	16	79	G3/8	M16x1,5	24	8	26	121	69	20	190	17	M8	17	56,5 ±0,5	4	4
80	40	45	17	100	G3/8	M20x1,5	30	10	33	128	86	25	214	16,5	M10	22	72 ±0,5	4	4
100	40	55	17	120	G1/2	M20x1,5	30	10	35,5	138	91	25	229	21	M10	22	89 ±0,5	4	4

Ø	WH	ZJ	ZM	weight	
				(3)	(4)
32	26	120	146	0,560	0,365
40	30	135	165	0,870	0,480
50	37	143	180	1,120	0,690
63	37	158	195	1,600	0,750
80	46	174	220	2,750	1,125
100	51	189	240	3,870	1,360

- (3) Cylinder weight with 0 mm stroke.
- (4) Weight to be added per additional 100 mm length.
- (5) Dimension SW changed as against standard AFNOR NFE 49 003.

	NFE 49 003	ISO 15552
Ø 50-63	16	17
Ø 80-100	21	22

Dimensional tolerances according to standard ISO 15552