

## SHUT-OFF VALVE AND SOFT-START UNITS

Modulair 107-112 ranges - G 1/8 to G 3/4  
solenoid/air operated

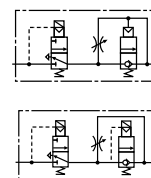

Series  
**343**  
Type  
Modulair

### PRESENTATION

- This unit provides two main functions:
  - **Pneumatic system venting.**
  - **Gradual pressurisation** after an outage leading to venting of the system.
- This product allows for machines and installations to conform to the European Directives.



### OPERATING PRINCIPLE

#### ■ SHUT-OFF VALVE

The 3/2 NC shut-off valve, controlled by a solenoid valve of the CNOMO pad-mounting type, vents the system by de-energising the solenoid valve.

#### ■ SOFT-START DEVICE

Upon pressurisation, when the soft-start device is in its initial position, an adjustable air flow ensures gradual filling of the downstream circuit, so that the actuators move slowly. The transition to the full flow position depends on which of the following soft-start devices is chosen:

##### • AUTOMATIC SOFT-START DEVICE (Modulair 107-112)

Automatic switch-over to the full flow position as soon as the downstream pressure reaches 60 to 70% of the supplied pressure (upstream pressure). Operating cycles take place at normal speed thereafter.

The soft-start device remains in the full flow position as long as the upstream pressure is maintained. The device returns into its initial position when the air supply is cut off.

##### • SOLENOID/AIR CONTROLLED SOFT-START DEVICE (Modulair 112)

This device, which complies to technical CNOMO specifications (E05.03.135.N), can be used to gradually feed air into the system whenever restarting after a shutdown or pressure cut-off. The system is slowly returned into the end-of-cycle position. As soon as this condition is reached, the solenoid pilot valve is energised in accordance with the automatic control **specified by the user**. The soft-start device then switches to the full-flow position allowing the subsequent operating cycles to take place at normal speed.

The solenoid pilot valve must be kept energised under normal operating conditions. Any de-energisation of the solenoid pilot valve sets the soft-start device into the low-flow position.

*Note: In both soft-start device versions, the filling rate, i.e. the pressure build-up in the downstream circuit, is adjusted by means of a fine-thread screw with can be locked to prevent unauthorised adjustment of regulated pressure.*

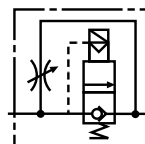
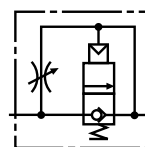
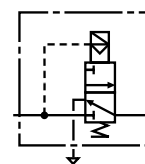

### MOUNTING AND OPERATING RECOMMENDATIONS

- The shut-off and soft-start valve unit must be mounted first in the pneumatic system, **after** the filter, filter/regulator or filter + regulator and **before** any lubricator (see examples below). The standard assembly kit (see accessories) enables direct connection of the unit to a FRL system of the MODULAIR type 107 or 112.

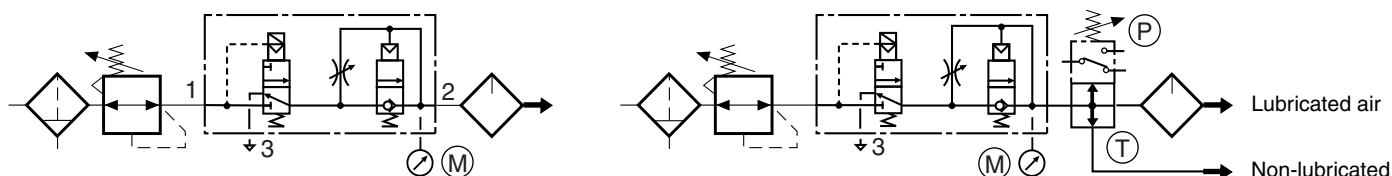

- (M) Matching pressure gauge for monitoring downstream pressure build-up (see accessories).  
A pressure gauge can also be mounted at the outlet of the shut-off valve.

(P) Matching pressure switch

(T) By-pass module

- **Do not obstruct exhaust port 3.** It is recommended to mount an exhaust silencer (available as accessory, see page 37).
- **The shut-off valve must only be de-energised in case of need** when the system is generally shutdown or in case of power supply failure.
- For systems which are operated only infrequently, **the correct functioning of the shut-off and soft start valve unit must be regularly checked - at least once per month -** (full exhaust and gradual pressurisation of the system).

**SYSTEM PRESSURISATION AND DEPRESSURISATION CURVES**

• WITH AUTOMATIC SOFT-START DEVICE

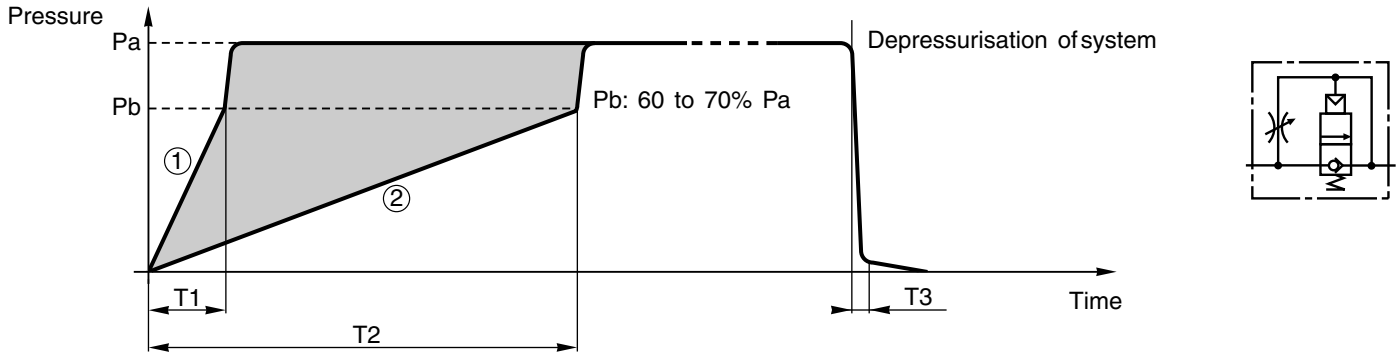

The adjustment range for the pressurisation time lies between curves (1) and (2).  
 The transition to full flow takes place automatically as soon as the downstream pressure reaches 60 to 70% of the upstream pressure.  
 Filling and venting times (in seconds):

|                                      | Modulair 107 | Modulair 112 |
|--------------------------------------|--------------|--------------|
| T1 (with screw loosened by 6 turns). | 11,5         | 8            |
| T2 (with screw loosened by 1 turn).  | 250          | 75           |
| T3 (venting time)                    | 6,5          | 2            |

These times correspond to a supply pressure (Pa) of 6.3 bar, a transition pressure (Pb) of 60% to 70% Pa (not adjustable) and a downstream system capacity of **10 litres**

• WITH A SOLENOID/AIR CONTROLLED SOFT-START DEVICE (Modulair 112 type only)

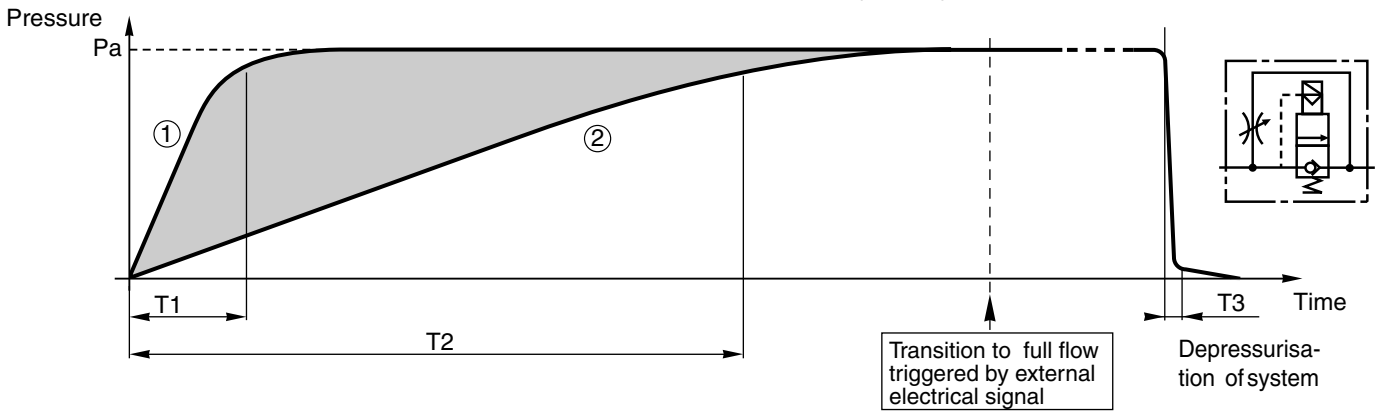

Unlike the automatic soft-start version, this version only authorises full flow on receiving a permanent electrical signal (see note below).  
 The adjustment range for the pressurisation time lies between curves (1) and (2).  
 Filling and venting times (in seconds):

|                                     | Modulair 112 |
|-------------------------------------|--------------|
| T1 (with screw loosened by 6 turns) | 12           |
| T2 (with screw loosened by 1 turn)  | 110          |
| T3 (venting time)                   | 2            |

These times correspond to a supply pressure (Pa) of 6.3 bar, a downstream system capacity of **10 litres** and a pressure of 90% Pa.

The full flow position is determined by the solenoid pilot valve which must be energised after checking that all the end-of-cycle sensors are activated. It also enables fast initiation of pressurisation if an emergency shutdown occurs at end of cycle (see curve A) or near end of cycle (see curves B<sub>1</sub>, B<sub>2</sub>, B<sub>3</sub>, etc.)  
 Minimum pressurisation time (curve A): 1s with an upstream pressure of 6.3bar and a capacity of 10 litres.

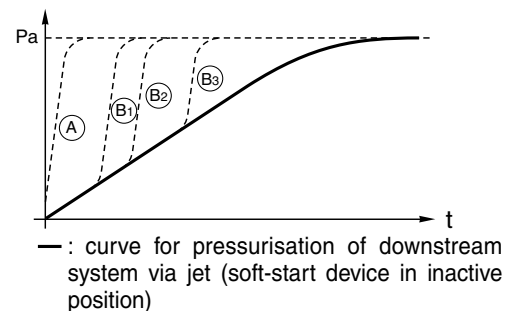

The solenoid/air controlled soft-start device also enables:

- Full flow operation in an "automatic" mode and slow speed operation in an "adjustment" mode for step-by-step manual setup.
- On returning to the "automatic" mode, carrying out one or more cycles at low speed (while the solenoid pilot valve is not energised).

00276GB-2009/R01 Availability, design and specifications are subject to change without notice. All rights reserved.



### SPECIFICATIONS

|                        | MODULAIR 107                        | MODULAIR 112                                  |
|------------------------|-------------------------------------|---|
| FLUID                  | :air filtered 25 µm, non-lubricated | :air filtered 25µm, non-lubricated            |
| PORTS                  | :G1/8 - G1/4                        | :G 1/4 - G 3/8 - G 1/2                        |
| OPERATING PRESSURE     | :2,5 to 10 bar                      | :3 to 10 bar                                  |
| MAX. FLOW (at 6.3 bar) | :1000 l/min (G1/8-G1/4)             | :1800 l/min (G1/4)<br>:2700 l/min (G3/8-G3/4) |
| AMBIENT TEMPERATURE    | :0°C to + 50°C                      | :0°C to + 50°C                                |

### CONSTRUCTION

#### VALVE AND SOFT-START DEVICE

Metal body  
Internal parts: brass and acetal resin (POM), nitrile seals (NBR)  
Steel micrometric screw and locking pin of steel  
Air flow direction indicated by arrow



#### PILOT SOLENOID VALVE CONSTRUCTION

|                              | Series 302                  | Series 189/190               | Series 192                           |
|------------------------------|-----------------------------|------------------------------|--------------------------------------|
| Body                         | : filled 6/6 polyamide (PA) | filled 6/6 polyamide (PA)    | filled polyarylamide (PAM)           |
| Seals                        | : nitrile (NBR)             | nitrile (NBR)                | nitrile (NBR) and polyurethane (PUR) |
| Electric equipment standards | : NF C 79300                | NF C 79300                   | NF C 79300                           |
| Coil and magnetic circuit    | : moulded monobloc type     | moulded monobloc type        | moulded monobloc type                |
| Exhaust connection           | : not collectable           | M5 (+ drain protector - 190) | G 1/8 (+ drain protector)            |
| Connector                    | : size 15                   | size 22 (189) - 30 (190)     | size 30                              |
| Protection class             | : IP65                      | IP65                         | IP65                                 |

### ELECTRICAL CHARACTERISTICS

| CNOMO mating surface  | valve serial No.   | Modulair 107 112             | voltage                            | consumption  |                | insulation class | connection  |
|-----------------------|--------------------|------------------------------|------------------------------------|--------------|----------------|------------------|---|
|                       |                    |                              |                                    | inrush       | holding        |                  |   |
| Size 15 (E06.36.120N) | 302                | ●                            | ~ 24 V, 115 V, 230 V - 50/60 Hz    | 2,6 VA (2 W) |                | F                | Spade plug size 15 connector, DIN43650, 9,4 mm, industry standard B, rotatable by 90° |
|                       |                    |                              | = 24 V                             | 1 W          |                |                  |   |
| Size 30 (E06.05.80)   | 189                | ● ●                          | ~ 24 V, 115 V, 230 V - 50 Hz       | 6 VA         | 3,5 VA (2,5 W) | F                | Spade plug size 22 connector, DIN43650, 11 mm, industry standard B, rotatable by 180° |
|                       |                    |                              | = 24 V                             | 2,5 W        |                |                  |   |
|                       | 190 <sup>(1)</sup> | ● ●                          | ~ 24 V, 48 V, 115 V, 230 V - 50 Hz | 9 VA         | 4 VA (3 W)     | F                | Spade plug size 30 connector, ISO4400/EN175301-803, form A, rotatable by 90°          |
|                       |                    |                              | = 12 V, 24 V, 48 V, 110 V          | 3 W          |                |                  |   |
| 192                   | ●                  | ~ 24 V, 115 V, 230 V - 50 Hz | 12 VA                              | 6 VA (4 W)   | F              |                  |   |
|                       |                    |                              | = 24 V                             | 5 W          |                |                  |   |

(1) The type 190 solenoid valve is dual voltage: (24 V~,12 V=)(48 V~, 24 V=)(115 V~,48 V=)(230 V~, 110 V=). Other voltage and 60Hz frequency, consult us.

### CHOICE OF COMPOSITION (Shut-off valve + soft-start units)

Products can be ordered separately (see page 41)

| fonction symbol | description  | MODULAIR type | CNOMO pilot | Ø port <sup>1</sup>              | 2 codes <sup>(2)</sup> for ordering |  |
|-----------------|--|---------------|-------------|----------------------------------|-------------------------------------|--|
|                 |  |               |             |                                  | shut-off valve + soft-start units   | + series 302,189,190 or 192 (M) solenoid valve ~ / = |
|                 | 3/2 NC shut-off valve and <b>automatic</b> NC 2/2 soft-start device (without silencer)             | 107           | size 15     | G 1/8                            | 34394013                            | + 1 x { 30211112--A (~) ▼                            |
|                 |  |               |             | G 1/4                            | 34394014                            | 30211112--D (=) ▼                                    |
|                 |  |               |             | G 1/8                            | 34394005                            | + 1 x { 18900007 X                                   |
|                 |  |               |             | G 1/4                            | 34394006                            | 19000005 X   |
|                 |  |               |             |                                  |                                     | 19000017 ▼   |
|                 |  |               |             |                                  |                                     | 19000017 ▼   |
|                 | 3/2 NC shut-off valve and <b>solenoid/air operated</b> NC 2/2 soft-start device (without silencer) | 112           | size 30     | G 1/4                            | 34393107                            | + 1 x { 18900007 X                                   |
|                 |  |               |             | G 3/8                            | 34393108                            | 19000005 X   |
|                 |  |               |             | G 1/2                            | 34393109                            | 19000017 X   |
|                 |  |               |             | G 3/4 (3)                        | 34393204                            | 19200007 ▼   |
|                 |  |               |             | non intended for the combinaison |                                     | 19200009 ▼   |
|                 |  |               |             | G 3/4                            | 34393200                            | 19200009 ▼   |
|                 | 3/2 NC shut-off valve and <b>solenoid/air operated</b> NC 2/2 soft-start device (without silencer) | 112           | size 30     | G 1/4                            | 34393110                            | + 2 x { 18900007 X                                   |
|                 |  |               |             | G 3/8                            | 34393111                            | 19000005 X   |
|                 |  |               |             | G 1/2                            | 34393112                            | 19000017 X   |
|                 |  |               |             | G 3/4 (3)                        | 34393206                            | 19200007 ▼   |
|                 |  |               |             | non intended for the combinaison |                                     | 19200007 X   |
|                 |  |               |             | G 3/4                            | 34393202                            | 19200009 ▼   |

(2) The unit (shut-off valve + soft-start device) and the solenoid valve(s) are ordered separately stating the quantity and code of each component. The solenoid valves are not supplied pre-installed on the system.

(M) Manual operator X : none ▼ : impulse. **Do not use locking manual operator**

NOTE: These products can be **pneumatically piloted** in which case it is necessary to separately order the pneumatic connection flange(s) (G1/8), code **881 26 401** instead of the above solenoid valves

(3) Version intended for the combination of various functions (FRL - isolation valve etc ...), select the desired functions and obtain the necessary assembly kits and mounting brackets (see page 42)

| accessories  | Modulair 107 code | Modulair 112 code |
|--|-------------------|-------------------|
| Assembly kit for connection to FRL                               | 34304001          | 34303001          |
| Set of 2 side mounting brackets                                  | 34304003          | 34303003          |
| Pressure gauge 0-12 bar (Mod. 107: Ø40 mm - Mod. 112: Ø50 mm)    | 34300041          | 34200062          |
| Sintered bronze silencer (to be placed under the shut-off valve) | 34600002          | 34600004          |
| Porous plastic silencer (to be placed under the shut-off valve)  | 34600407          | 34600409          |

### OPTION

• For equipment and pilot valves intended for use in potentially **explosive atmospheres**, caused by gases or dusts, in accordance with ATEX Directive 94/9/EC, consult our ATEX - X019 catalogue

All leaflets are available on: [www.asconumatics.eu](http://www.asconumatics.eu)

### SHUT-OFF VALVE + AUTOMATIC SOFT-START DEVICE (MODULAIR 107 and 112)

G1/8 to G1/2

G3/4

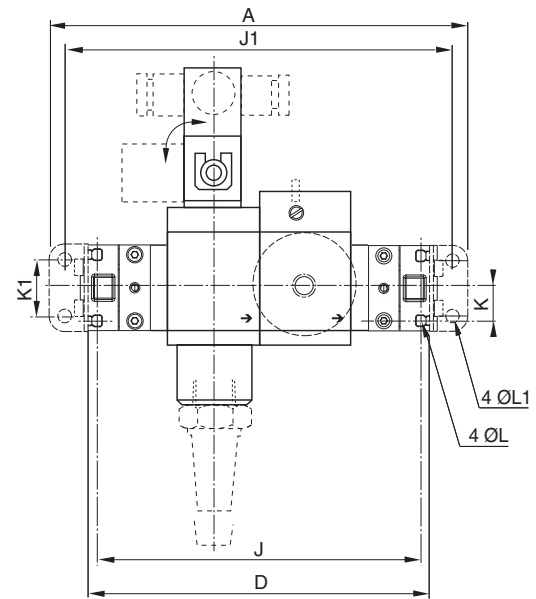
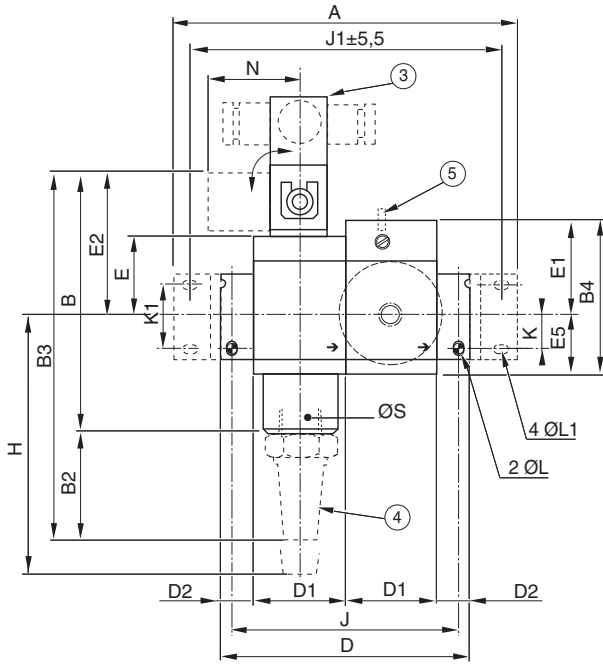

Note: Solenoid valve coils and connectors rotatable by 90° and 180° increments

- connector size 15 - series 302 pilot
- connector size 22 - series 189 pilot
- connector size 30 - series 190 or 192 pilot

|             | Modulair range |               |               |
|-------------|----------------|---------------|---------------|
|             | 107            | 112           | 112           |
| Ø W         | G1/8           | G1/4          | G1/2          |
|             | G1/4           | G3/8          | G3/4          |
| A           | 125            | 171           | 213           |
| B           | 122            | 140,5 (146,5) | 140,5 (146,5) |
| B1          | 173 [147]      | 182,5 (179,5) | 182,5 (179,5) |
| B2          | 34             | 56            | 56            |
| B3          | 158            | 196,5 (202,5) | 196,5 (202,5) |
| B4          | 71             | 80            | 80            |
| C           | 42             | 55            | 55            |
| C1          | 74 [54]        | 73 (100)      | 73 (100)      |
| C2          | 93 [73]        | 92 (119)      | 88 (115)      |
| C4          | 38             | 47,5          | 55            |
| D           | 84             | 125           | 173           |
| D1          | -              | 46            | 46            |
| D2          | -              | 16,5          | -             |
| E           | 45 [55]        | 41            | 41            |
| E1          | 45             | 49            | 49            |
| E2          | 75             | 73 (79)       | 73 (79)       |
| E3          | 126 [100]      | 115 (112)     | 115 (112)     |
| E4          | 47             | 67,5          | 67,5          |
| E5          | 26             | 31            | 31            |
| F           | 21             | 27,5          | 27,5          |
| F1          | 40             | 46            | 42            |
| H           | 89             | 135,5         | 135,5         |
| J           | 74             | 116           | 164           |
| J1          | 110,5          | 155           | 197           |
| K           | 10             | 17            | 17            |
| K1          | 28             | 33,5          | 29            |
| Ø L         | 4,1            | 5,5           | 4             |
| ØL1         | 4,5            | 5,5           | 7             |
| M           | 3              | 4             | 2             |
| N           | 57 [37]        | 57 (56)       | 57 (56)       |
| ØS          | G1/4           | G1/2          | G1/2          |
| Weight (kg) | 0,800 [0,670]  | 1,400 (1,550) | 1,730 (1,880) |

DIRECT FRONTAL MOUNTING ① OR LATERAL (G3/4)

MOUNTING WITH BRACKETS

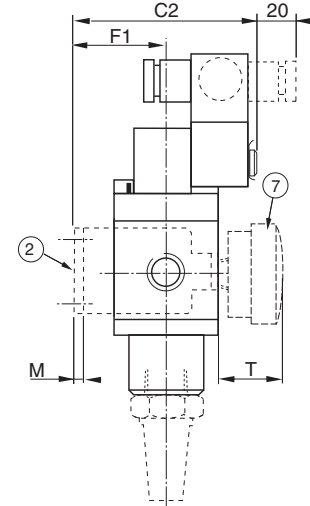
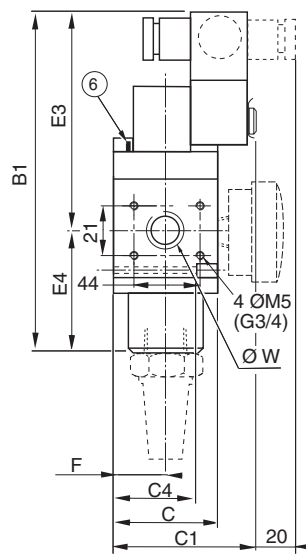

- ① Direct frontal mounting (G1/8 - G1/2) : 2 holes ØL and depth C4
- ② Mounting with 2 side brackets (accessory)
- ③ Pilot (supplied separately): série 302,189 or 190 (Mod. 107) - série 189,190 or 192 (Mod. 112)
- ④ Matching silencer (accessory)
- ⑤ Adjustment locking pin
- ⑥ Solenoid valve installation polariser
- ⑦ Pressure gauge or electronic pressure switch on front of soft-start device or shut-off valve. (dimension T : gauge = 34 ; pressure switch = 50)



Standard weights and dimensions correspond to a series 190 solenoid valve.

[ ] : dimensions and weight with series 302 solenoid valve

( ) : dimensions and weight with series 192 solenoid valve



### SHUT-OFF VALVE + SOLENOID/AIR CONTROLLED SOFT-START DEVICE (MODULAIR 112)

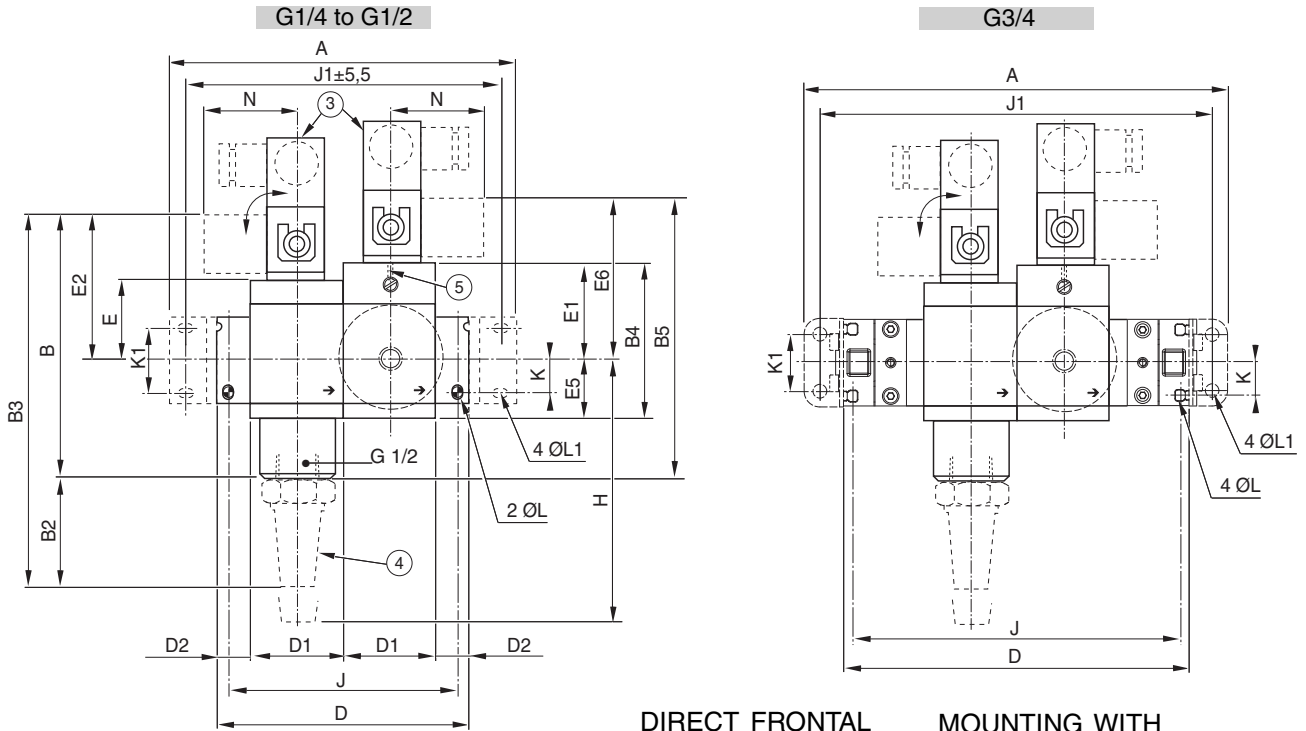

Note: Solenoid valves and connectors rotatable by 90° increments, size 30 connector

| Ø W         | type Modulair |               |
|-------------|---------------|---------------|
|             | 112           | 112           |
|             | G1/4          | G3/4          |
|             | G3/8          | G3/4          |
|             | G1/2          |               |
| A           | 171           | 213           |
| B           | 140,5 (146,5) | 140 (146,5)   |
| B1          | 190,5 (187,5) | 190,5 (187,5) |
| B2          | 56            | 56            |
| B3          | 196,5 (202,5) | 196,5 (202,5) |
| B4          | 80            | 80            |
| B5          | 148,5 (154,5) | 148,5 (154,5) |
| C           | 55            | 55            |
| C1          | 73 (100)      | 73 (100)      |
| C2          | 92 (119)      | 88 (115)      |
| C4          | 47,5          | 55            |
| D           | 125           | 173           |
| D1          | 46            | 46            |
| D2          | 16,5          | -             |
| E           | 41            | 41            |
| E1          | 49            | 49            |
| E2          | 73 (79)       | 73 (79)       |
| E3          | 123 (120)     | 123 (120)     |
| E4          | 67,5          | 67,5          |
| E5          | 31            | 31            |
| E6          | 81 (87)       | 81 (87)       |
| F           | 27,5          | 27,5          |
| F1          | 46            | 42            |
| H           | 135,5         | 135,5         |
| J           | 116           | 164           |
| J1          | 155           | 197           |
| K           | 17            | 17            |
| K1          | 33,5          | 29            |
| Ø L         | 5,5           | 4             |
| Ø L1        | 5,5           | 7             |
| M           | 4             | 2             |
| N           | 57 (56)       | 57 (56)       |
| Weight (kg) | 1,520 (1,820) | 1,850 (2,150) |

( ) : dimensions and weight with series 192 solenoid valve

DIRECT FRONTAL MOUNTING ① OR LATERAL (G3/4)

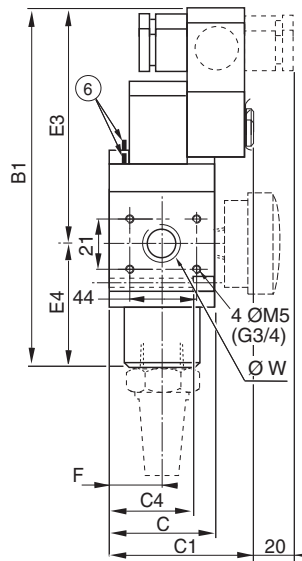

MOUNTING WITH BRACKETS

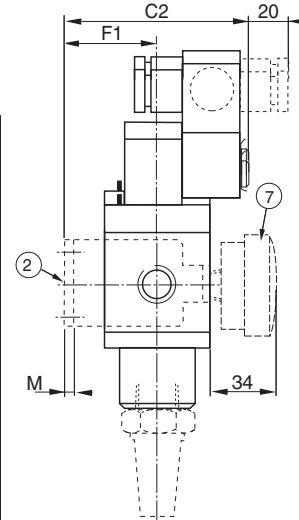

- ① Direct frontal mounting (G1/4 - G1/2) : 2 holes ØL and depth C4
- ② Mounting with 2 side brackets (accessory)
- ③ 190 ou 192 series pilot solenoid valves (supplied separately)
- ④ Matching G 1/2 silencer (accessory)
- ⑤ Adjustment locking pin
- ⑥ Solenoid valve installation polariser
- ⑦ Pressure gauge on front of soft-start device or shut-off valve



### SPECIFICATION OF EQUIPMENT SUPPLIED SEPARATELY

| MODULAIR type | CNOMO pilot | port sizes                       | code                                  |  |  |          |  |  |  |
|---------------|-------------|----------------------------------|---------------------------------------|--|--|----------|--|--|--|
|               |             |                                  | shut-off valve (**)<br>solenoid valve | automatic soft-start device  | solenoid/air controlled soft-start device (**) |          |  |  |  |
| 107           | size 15     | G1/8                             | 34394009                              | + } 30211112--A (~) (▼)<br>30211112--D (=) (▼)                                   | 34304021                                       | -        |  |  |  |
|               |             | G1/4                             | 34394010                              |  | 34304022                                       | -        |  |  |  |
|               | size 30     | G1/8                             | 34394001                              | + } 18900007 (x)<br>19000005 (x)<br>19000017 (▼)                                 | 34304021                                       | -        |  |  |  |
|               |             | G1/4                             | 34394002                              |  | 34304022                                       | -        |  |  |  |
| 112           | size 30     | G1/4                             | 34393101                              | + } 18900007 (x)<br>19000005 (x)<br>19000017 (▼)<br>19200007 (x)<br>19200009 (▼) | 34303019                                       | 34393004 |  |  |  |
|               |             | G3/8                             | 34393102                              |  | 34303020                                       | 34393005 |  |  |  |
|               |             | G1/2                             | 34393103                              |  | 34303021                                       | 34393006 |  |  |  |
|               |             | G3/4 (1)                         | 34393194                              |  | 34303198                                       | 34393198 | + } 18900007 (x)<br>19000005 (x)<br>19000017 (▼)<br>19200007 (x)<br>19200009 (▼) |  |  |
|               |             | non intended for the combinaison |                                       |  |  |          |  |  |  |
|               |             | G3/4                             | 34393192                              |  | 34303196                                       | 34393196 |  |  |  |

(\*\*) The products + solenoid pilot valve must be ordered separately stating the quantity and code of each component, the solenoid valves are not supplied pre-installed on the system.

- For Size 15 series 302 valves, the codes of the AC and DC versions are different.
- For Size 30 series 190 and 192, the codes vary with the type of manual operator: (x) = none, (▼) = impulse

NOTE: These products can be **pneumatically piloted** in which case it is necessary to separately order the pneumatic connection flange(s) (G1/8), code **88126401**, instead of the above solenoid valves.

(1) Version intended for the combination of various functions (FRL - isolation valve etc ...), select the desired functions and obtain the necessary assembly kits and mounting brackets (see page 42)

**OPTION:** • For equipment and pilot valves intended for use in potentially **explosive atmospheres**, caused by gases or dusts, in accordance with ATEX Directive 94/9/EC, consult our ATEX - X019 catalogue

### DIMENSIONS SHUT-OFF VALVE

Weights:  
 Modulaire 107 avec pilote 302: 0,350 kg  
 Modulaire 107 avec pilote 189: 0,450 kg / 190: 0,510 kg  
 Modulaire 112 avec pilote 189: 0,810 kg  
 Modulaire 112 avec pilote 190: 0,870 kg / 192: 0,990 kg

### SOFT-START DEVICE

#### AUTOMATIC

0,290 kg  
0,750 kg

#### SOLENOID/AIR CONTROLLED

(Modulaire 112 only)

189: 0,810 kg  
190: 0,870 kg / 192: 0,990 kg

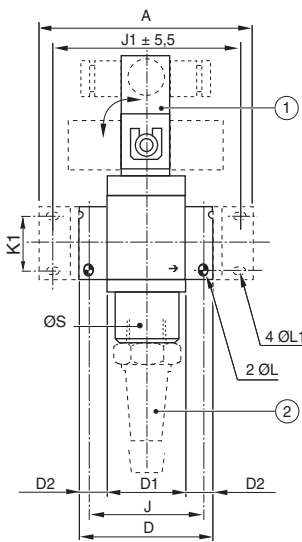

#### G3/8 to G1/2 versions

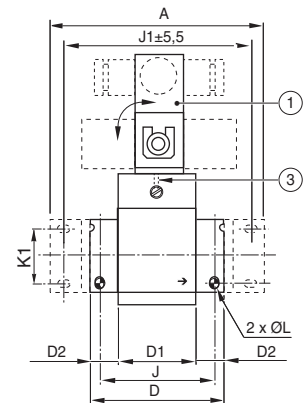
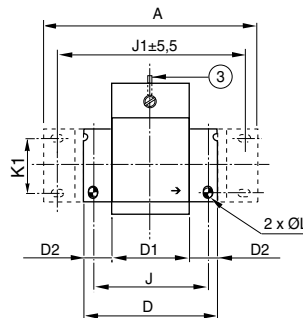

#### G3/4 VERSION (all versions)

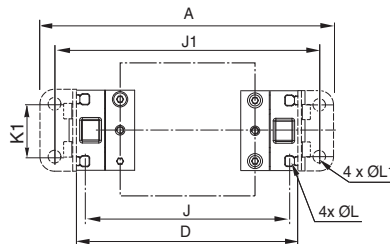

| range | Modulaire    |                      |      |
|-------|--------------|----------------------|------|
|       | 107          | 112                  | 112  |
| Ø W   | G1/8<br>G1/4 | G1/4<br>G3/8<br>G1/2 | G3/4 |
| A     | 83           | 125                  | 191  |
| D     | 42           | 79                   | 127  |
| D1    | -            | 46                   | 46   |
| D2    | -            | 16,5                 | -    |
| J     | 32           | 70                   | 118  |
| J1    | 68,5         | 109                  | 151  |
| K1    | 28           | 33,5                 | 29   |
| Ø L   | 4,1          | 5,5                  | 4    |
| ØL1   | 4,5          | 5,5                  | 7    |
| ØS    | G1/4         | G1/2                 | G1/2 |

- ① Pilot (supplied separately): série 302,189 or 190 (Mod. 107) - série 189,190 or 192 (Mod. 112)
- ② Matching silencer (accessory)
- ③ Adjustment locking pin

Note: Solenoid valve coils and connectors rotatable by 90° and 180° increments  
 - connector size 15 CM6 (Pg 7P) series 302 pilot  
 - connector size 22 CM8 (Pg 9P) series 189 pilot  
 - connector ISO 4400 CM10 (Pg 11P) series 190 or 192 pilot

For overall dimensions of direct frontal or bracket mounting, see preceding pages.

### ASSEMBLY OPTION FOR VALVE AND SOFT-START DEVICES ORDERED SEPARATELY

It is possible to combine components ordered separately using the assembly kit and side-mounting brackets for installation. Accessories needed (see page 38)

