

# "H" GUIDING UNIT

suitable for ISO 15552-AFNOR-DIN air cylinders  
Ø 32 to 100 mm  
with 4 slide or ball bearings

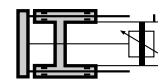

Series  
**450-453**  
Type  
**PES**

## CONSTRUCTION

- GUIDING UNIT WITH SLIDE BEARINGS**
- Single block unit, metal body
  - 4 bronze sintered self-lubricating roller bearings
  - 2 chrome-plated steel guiding rods
  - Lip seals on the guiding rods

- GUIDING UNIT WITH BALL BEARINGS**
- Monolithic construction
  - 4 linear ball bearings
  - 2 hardened guiding rods
  - Lip seals on the guiding rods
  - 2 type KP2K DIN 51825 grease nipples

High quality components with the following characteristics:

- High admissible loads
- Accurate guiding
- High sturdiness
- Excellent mobility, low wear and long life with the linear ball bearings
- The cylinder rod is fixed to the guiding unit by means of an alignment compensation bracket

## CYLINDER ADAPTATIONS

- Double-acting PES type-Series 450, 453 standard ISO 15552-AFNOR ISO 15552-DIN ISO 15552
- With profiled tube plate (see P229) or with tie rods (see P232)
- With or without pneumatic cushioning
- Ready to receive magnetic position detectors or not

## SPECIFICATIONS

FLUID	: Air or neutral gas, filtered, lubricated or NOT
PRESSURE	: 10 bar max.
TEMPERATURE	: -20°C, +70°C
MIN. STROKE (with detectors)	: 110 mm
MAX. STROKE	: 500 mm (other strokes on request)
MAX. SPEED	: 1 m/s
CONSTRUCTION	: as per <b>CNOMO E06.28.510.N</b> recommendation

## MOUNTINGS

- Guiding unit on frame: 3 mounting options using 4 tapped holes (on the 2 smallest sides or on one of the large sides), more 2 holes for centring.
- Load on the guiding unit: 2 options, using 4 tapped holes or using 4 countersunk holes, more 2 holes for centring.

**ORDERING** When ordering, please specify:

### ■ CYLINDER + GUIDING UNIT

- Standard code or reference for the PES cylinder \_\_\_\_\_ **450** .. ... (see P232)  
**453** .. ... (see P229)
- Optional code of the guiding unit \_\_\_\_\_

See documentation P229 on PES cylinders series 453 with profiled barrel to define the position and the choice of grooves in relation to the guiding unit.

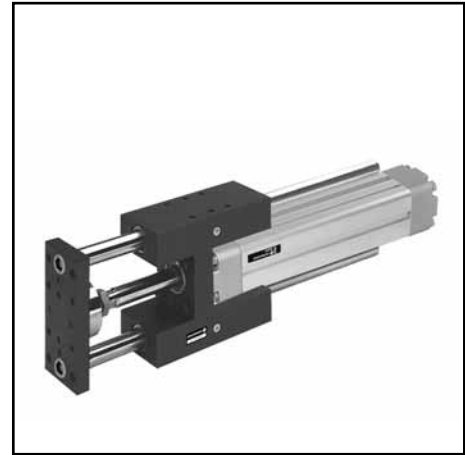

For other characteristics, see leaflet P229 or P232

Cylinder stroke * (mm)	CODE OF THE GUIDING UNIT WITH SLIDE BEARINGS						CODE FOR GUIDING UNIT WITH BALL BEARINGS					
	Ø 32**	Ø 40	Ø 50	Ø 63	Ø 80	Ø 100	Ø 32	Ø 40	Ø 50	Ø 63	Ø 80	Ø 100
50	010762	010770	010778	010786	010794	010802	010653	010661	010669	010677	010685	010693
80	010844	010846	010848	010850	010852	010854	010856	010858	010860	010862	010864	010866
100	010763	010771	010779	010787	010795	010803	010654	010662	010670	010678	010686	010694
125	010845	010847	010849	010851	010853	010855	010857	010859	010861	010863	010865	010867
160	010764	010772	010780	010788	010796	010804	010655	010663	010671	010679	010687	010695
200	010765	010773	010781	010789	010797	010805	010656	010664	010672	010680	010688	010696
250	010766	010774	010782	010790	010798	010806	010657	010665	010673	010681	010689	010697
320	010767	010775	010783	010791	010799	010807	010658	010666	010674	010682	010690	010698
400	010768	010776	010784	010792	010800	010808	010659	010667	010675	010683	010691	010699
500	010769	010777	010785	010793	010801	010809	010660	010668	010676	010684	010692	010700

\* Other strokes on request

### ■ GUIDING UNIT ALONE :

Cylinder stroke * (mm)	CODE OF THE GUIDING UNIT WITH SLIDE BEARINGS						CODE FOR GUIDING UNIT WITH BALL BEARINGS					
	Ø 32	Ø 40	Ø 50	Ø 63	Ø 80	Ø 100	Ø 32	Ø 40	Ø 50	Ø 63	Ø 80	Ø 100
50	88145176	88145184	88145192	88145201	88145209	88145217	88145062	88145070	88145078	88145086	88145094	88145103
80	88145282	88145284	88145286	88145288	88145290	88145292	88145294	88145296	88145298	88145300	88145302	88145304
100	88145177	88145185	88145193	88145202	88145210	88145218	88145063	88145071	88145079	88145087	88145095	88145104
125	88145283	88145285	88145287	88145289	88145291	88145293	88145295	88145297	88145299	88145301	88145303	88145305
160	88145178	88145186	88145194	88145203	88145211	88145219	88145064	88145072	88145080	88145088	88145096	88145105
200	88145179	88145187	88145195	88145204	88145212	88145220	88145065	88145073	88145081	88145089	88145097	88145106
250	88145180	88145188	88145196	88145205	88145213	88145221	88145066	88145074	88145082	88145090	88145098	88145107
320	88145181	88145189	88145197	88145206	88145214	88145222	88145067	88145075	88145083	88145091	88145099	88145108
400	88145182	88145190	88145198	88145207	88145215	88145223	88145068	88145076	88145084	88145092	88145101	88145109
500	88145183	88145191	88145199	88145208	88145216	88145224	88145069	88145077	88145085	88145093	88145102	88145110

\* Other strokes on request

All leaflets are available on: [www.ascojoucomatic.com](http://www.ascojoucomatic.com)

■ **MINIATURE MAGNETIC POSITIONS DETECTORS**

The magnetic position detectors are ordered separately:

- "T" model (see page P291), "COMPACT" model (see page P293), reed switch or magneto-resistive type
- "BIM" model, magneto-inductive (see page P297)

\*\* In the case of use of a BIM magnetic detector on PES series 450 Ø 32, it is necessary to add the option code = 995125

• **Front position control** (rod out): Its mounting excepted, the magnetic position detector and its electrical characteristics are identical to the detector used for the PES cylinders.

• **Rear position control** (rod in): Detector and support are identical to those used for PES cylinders.

**Min. stroke (mm) of series 450 type PES cylinders with tie-rods and magnetic position detection**

	Ø32	Ø40	Ø50	Ø63	Ø80	Ø100
detectors on one tie-rod	65	60	85	85	100	100
detectors on different tie-rods	50	50	75	65	80	75

**B**

● **MAXIMUM ADMISSIBLE LOAD "F" ON THE ROD END**

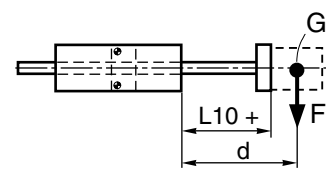
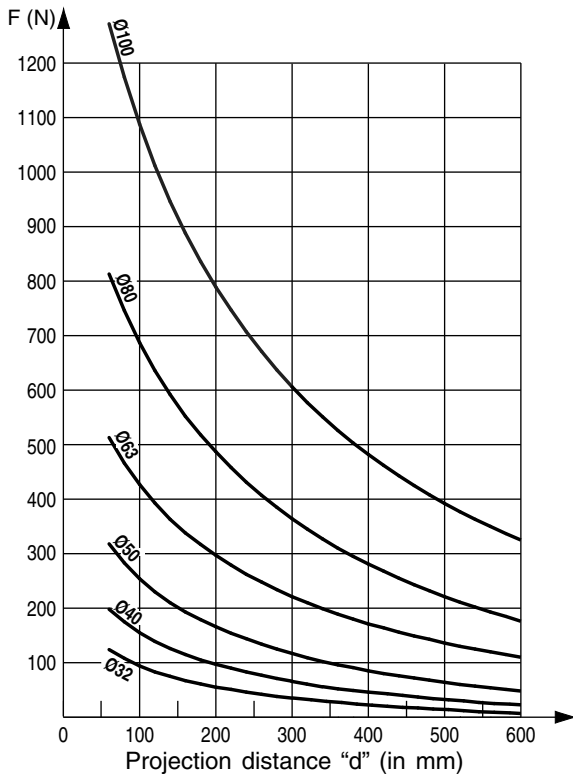

d = the projection distance (in mm) corresponding to the dimension L10 + the stroke length + the distance from the load centre of gravity (G) to the mating surface of the cylinder flange

**Note:**

The values in the opposite chart correspond to those in regular horizontal movement of the guiding unit with the rods in the same horizontal plane. In the case of vibration or jerky movement, **halve** the maximum allowable load values.

● **DETERMINING THE DEFLEXION**

Deflection under load as a function of projection distance "d", corresponds to the sum of no-load deflection  $f_0$  and flection  $f_{10}$  under load, the latter being proportional to the deflection caused by 10 N.

d = projection distance (in mm) as defined above.

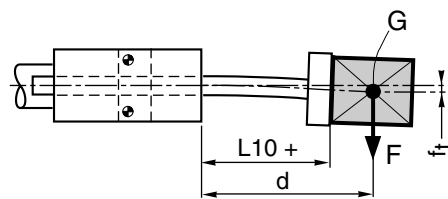

$$f_t = f_0 + \left( f_{10} \times \frac{F}{10} \right)$$

- $f_t$  = Total deflection (in mm)
- $f_0$  = Deflection without a load (in mm)
- $f_{10}$  = Deflection with a load of 10 N (in mm)
- F = Load on the rod ends (in N)

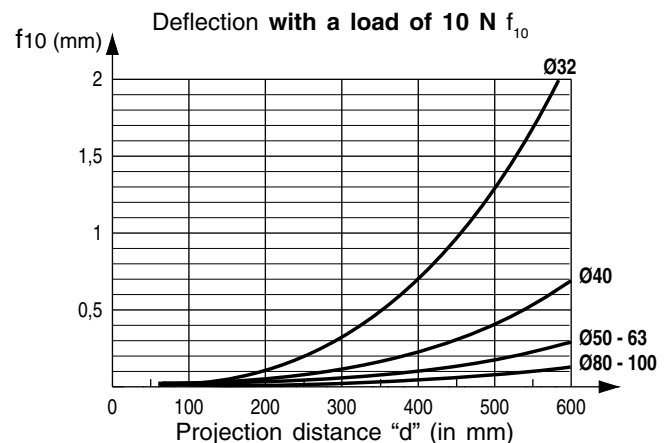
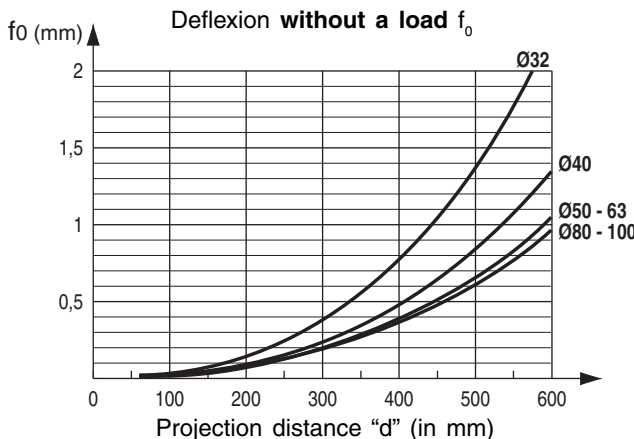

● **MAXIMUM ADMISSIBLE LOAD "F" ON THE ROD END**

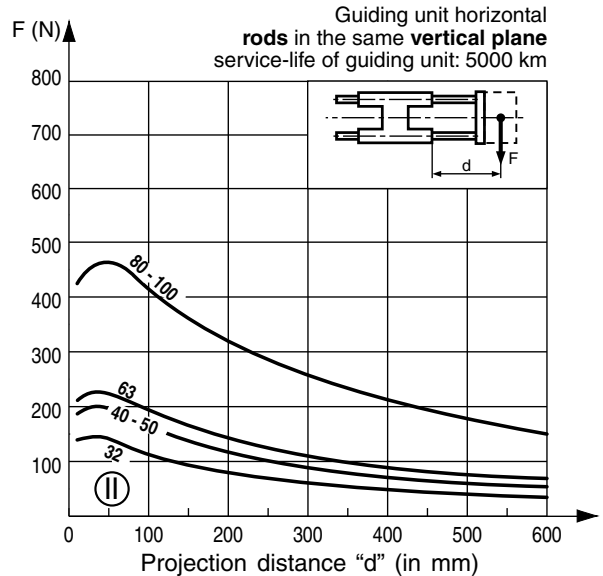
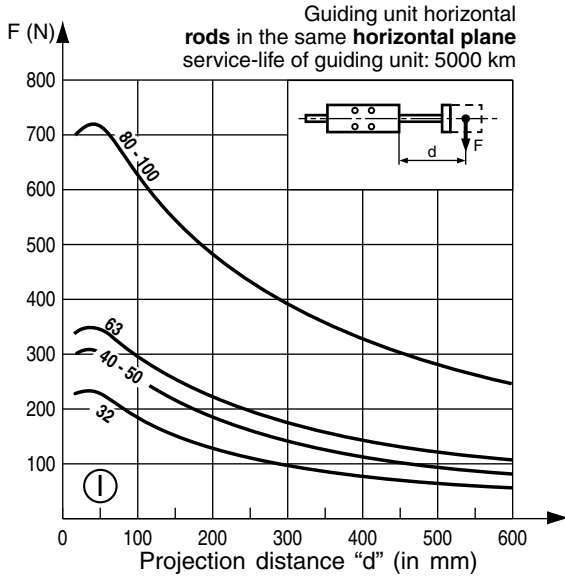

● **MAXIMUM ALLOWABLE MOMENTS "Ms" AT ROD END**

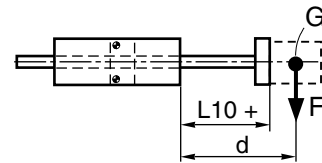
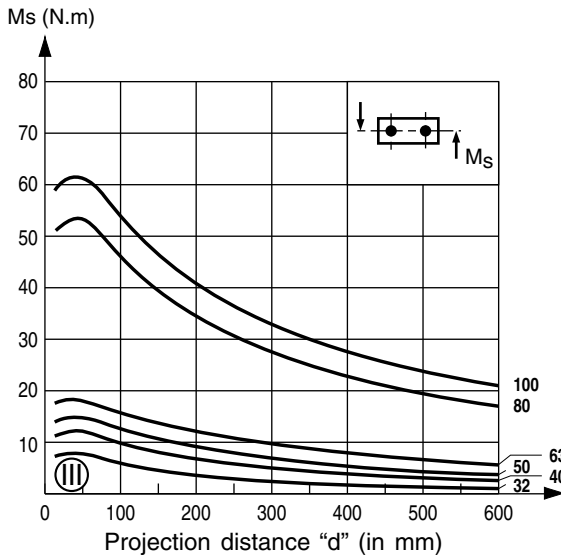

d = the projection distance (in mm) corresponding to the dimension L10 + the stroke length + the distance from the load centre of gravity (G) to the mating surface of the cylinder flange

**Note:** the values in charts (I), (II) and (III) correspond to those in regular horizontal movement. In the event of vibration or jerky movement, **halve** the maximum allowable values.

Whatever the stroke of the cylinder, its movement is only a small proportion of the travel (not more than 60 mm), it is necessary to reduce the maximum allowable torques and loads by multiplying the values taken from charts (I), (II) and (III) by coefficient K from chart (IV). For short travels which do not exceed 60 mm, the curves allow for this reduction in performance.

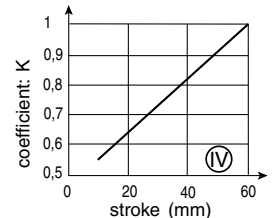

● **DETERMINING THE DEFLEXION**

Deflection under load as a function of projection distance "d", corresponds to the sum of no-load deflection  $f_0$  and flection  $f_{10}$  under load, the latter being proportional to the deflection caused by 10 N.

d = projection distance (in mm) as defined above.

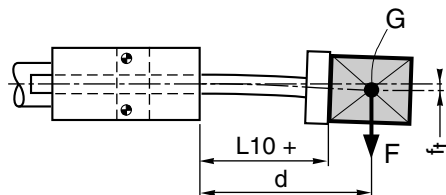

$$f_t = f_0 + \left( f_{10} \times \frac{F}{10} \right)$$

$f_t$  = Total deflection (in mm)  
 $f_0$  = Deflection without a load (in mm)  
 $f_{10}$  = Deflection with a load of 10 N (in mm)  
 F = Load on the rod ends (in N)

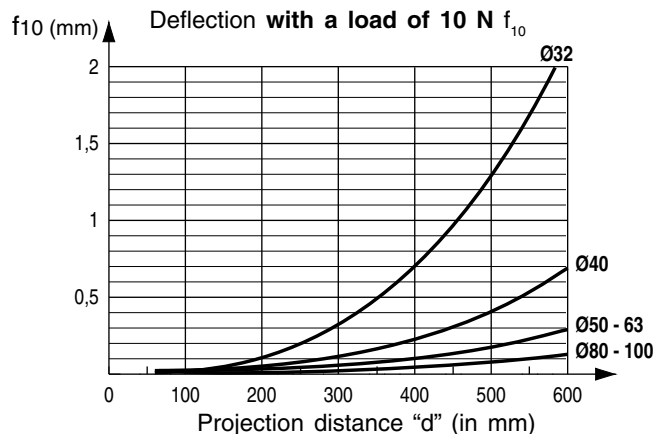
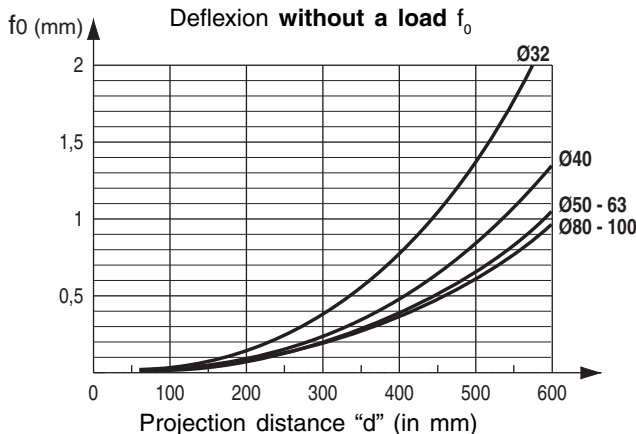

**DIMENSIONS (mm), WEIGHT (kg)**   
(Dimensions conforming with CNOMO E06.28.510.N)

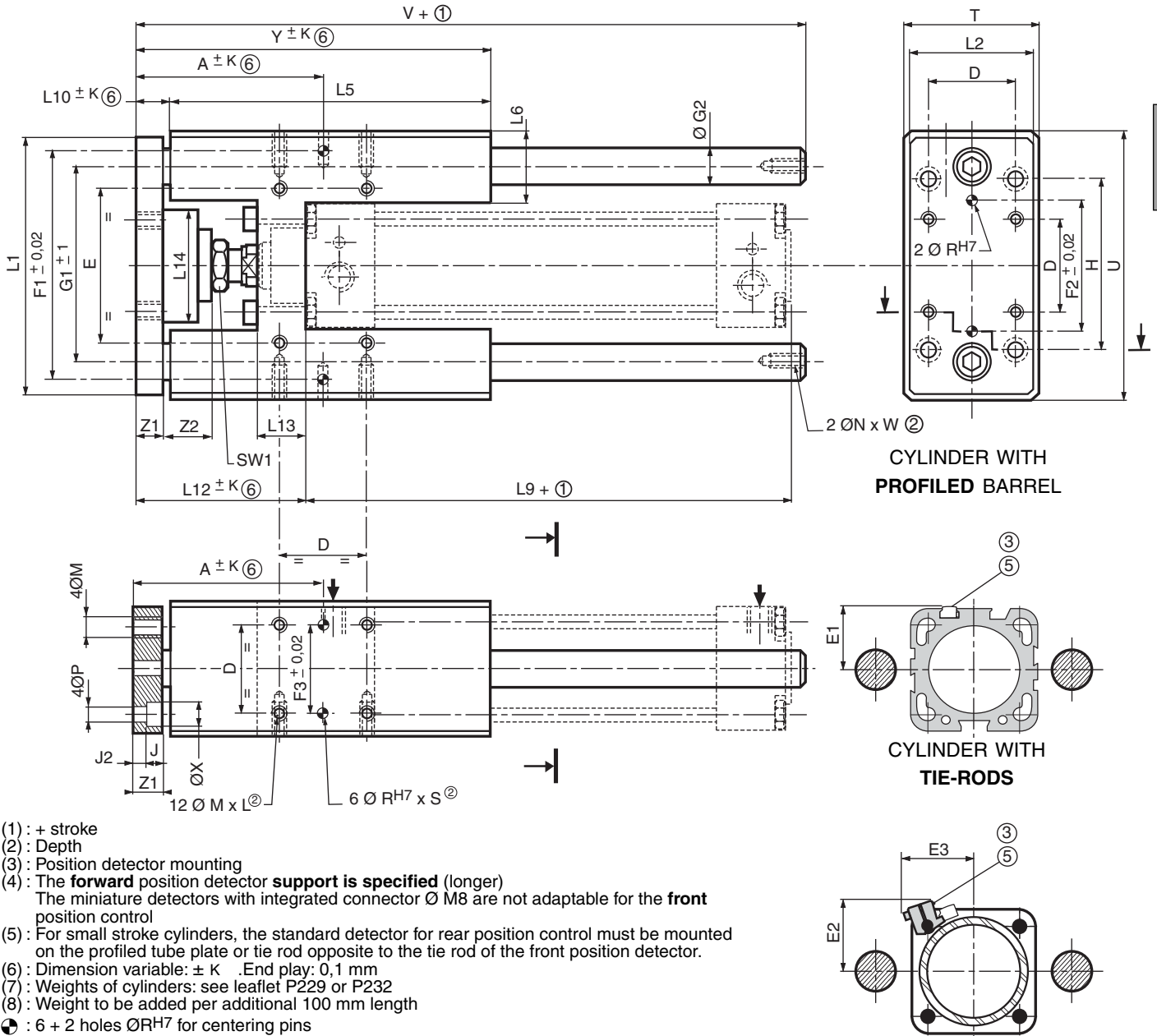

- (1): + stroke
- (2): Depth
- (3): Position detector mounting
- (4): The **forward** position detector **support is specified** (longer)  
The miniature detectors with integrated connector Ø M8 are not adaptable for the **front** position control
- (5): For small stroke cylinders, the standard detector for rear position control must be mounted on the profiled tube plate or tie rod opposite to the tie rod of the front position detector.
- (6): Dimension variable:  $\pm K$  End play: 0,1 mm
- (7): Weights of cylinders: see leaflet P229 or P232
- (8): Weight to be added per additional 100 mm length
- : 6 + 2 holes ØRH7 for centering pins

NOTE: The guiding units with a linear ball bearings must be lubricated every 3000 km, and more frequently if they are used in dusty surroundings

Ø	A	D	E	E1	E2	E3	F1 ± 0,02	F2 ± 0,02	F3 ± 0,02	G1	G2	H	J	J2	K	L	L1	L2	L5	L6	L9
32	78,5	32,5	61	42	44	30	81	50	32,5	74	12	78	6,5	5,5	2,5	12	90	45	130	23,2	98
40	85	38	69	45	47	34	99	54	38	86,7	16	84	6,5	5,5	3	12	110	54	140	28,3	109
50	97	46,5	85	51	51	42	119	72	46,5	103,7	20	100	9	6	4	16	130	63	150	33,3	110
63	106	56,5	100	55	56	47	132	82	56,5	118,7	20	105	9	6	4	16	145	80	182	33,3	125
80	130	72	130	64	63	55	166	106	72	147	25	130	11	9	5	20	180	100	215	40,5	132
100	140,5	89	150	71	75	-	190	131	89	173	25	150	11	9	5	20	200	120	220	40,8	142

Ø	L10	L12	L13	L14	M	N	P	R (H7)	S	SW1	T	U	V	W	X	Y	Z1	Z2	weight guiding unit		
																			slide bearings	(7) ball bearings	(8)
32	17,5	71,5	17	45	M6	M6	6,6	6	10	16	50	97	182	11	11	147,5	12	25	1,452	1,502	0,178
40	18	77	21	46	M6	M6	6,6	6	10	18	58	115	192	11	11	158	12	25	2,203	2,298	0,316
50	22	92,5	25	55	M8	M8	9	6	10	24	70	137	237	16	15	172	15	28	3,697	3,787	0,492
63	22	93	25	68	M8	M8	9	6	10	24	85	152	237	16	15	204	15	28	5,077	5,167	0,492
80	28	115	34	90	M10	M10	11	6	10	30	105	188	280	16	18	243	20	33	9,257	9,427	0,770
100	28,5	120,5	39	90	M10	M10	11	6	10	30	130	214	280	16	18	248,5	20	33	11,542	11,712	0,770

00244GB-2006/R01  
Availability, design and specifications are subject to change without notice. All rights reserved.

