

B

APPLICATION PRINCIPLE

The dynamic rod-locking device which is fitted to the series 450-453 cylinders type PES with profiled barrel or tie-rods is designed to stop and hold the rod of the cylinder under load in the event of air pressure or power failure. The rod lock device is an elastic mechanical device acting on brake pads. It is disengaged when pressure is applied.

THIS PRODUCT IS NOT A SAFETY COMPONENT

Advantages

- Stops and holds the piston rod at any point of its stroke.
- Holds maximum allowable cylinder load without drifting.
- **Locks in case of absence of air.**
- Two-directional action.
- Cast iron brake pads, **concentric on the rod, ensure the system's long service life without damaging the piston rod.**
- **Easy to install. Compact rod-locking device with dimensions approximately equal to those of the standard cylinder.**
- Any mounting position.
- Reduced weight (light metal alloy body).
- Possibility of mounting to cylinders complying with ISO 15552-AFNOR-DIN standards (longer rod, without front bushing).

The following options and versions cannot be fitted to this cylinder with rod-locking device:

- Stainless steel piston rod
- Reinforced piston rod
- High temperature version
- Barrel in glass-fibre reinforced epoxy resin
- U and H guiding units

OPERATING PRINCIPLE

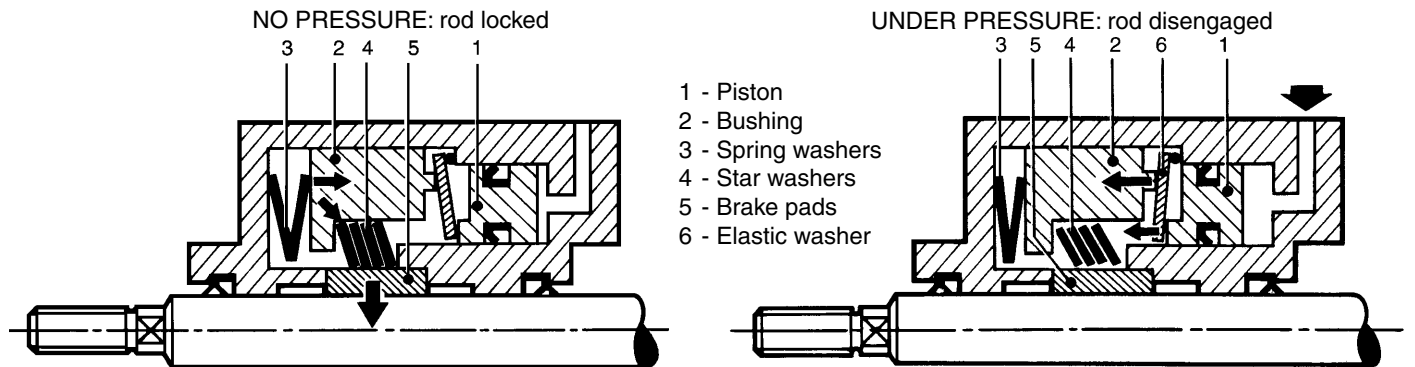

DYNAMIC ROD LOCK DEVICE IN ABSENCE OF PRESSURE

No force is transmitted to the pneumatic piston (1). The two spring washers (3) apply an axial force to the bushing (2) which transmits it to the star washers (4). The star washers apply a radial force to the brake pads (5) which lock the piston rod.

DYNAMIC ROD LOCK DEVICE UNDER PRESSURE (min. 4 bar, max. 8 bar)

The pressure exerts a force on the pneumatic piston (1) which transmits it to the elastic washer (6). This acts as a lever and gears down the force on the bushing (2). The bushing compresses the spring washers (3), all restraint is removed from the star washers (4) and brake pads (5). The rod is disengaged.

DYNAMIC RESTRAINT

The cylinder must be locked only in case of need in the event of an emergency shutdown or in case of power or pressure supply failure.

The rod-locking device can, however, be activated in every cycle as soon as the cylinder has come to a stop (hold function).

The stopping precision of the cylinder depends on:

- the cylinder's fitting position (horizontal or vertical);
- the load being moved by the cylinder;
- the rate of speed at which the load is moved;
- the response time of the downstream pneumatically or electrically operated valves;
- the air volume and opening area between the rod lock's control valve and its supply port.

DYNAMIC LOCKING CAPACITY: Maximum load between 80 and 590 kg according to speed and cylinder diameter.

STATIC HOLDING CAPACITY: Maximum force between 1000 and 6300 N according to cylinder diameter (see overleaf).

00242GB-2011/R01 Availability, design and specifications are subject to change without notice. All rights reserved.

GENERAL SPECIFICATIONS

ASSEMBLY	: Rod lock device incorporated into cylinder, fitted in line, centered on the piston rod (cylinder without front bushing).
CYLINDER	
CYLINDER TYPE	: Series 450 or 453 cylinder type PES conforming to ISO 15552-AFNOR NF ISO 15552-DIN ISO 15552 standards, aluminium barrel, pneumatically adjustable cushioning, designed for Reed switches, magneto-resistive or magneto-inductive position detectors.
CYLINDER BORE DIAMETERS	: Ø 40-50-63-80-100 mm.
STANDARD CYLINDER STROKES	: 50 to 600 mm (or more, consult us).
AMBIENT TEMPERATURE	: -20°C to +70°C
FITTING POSITION	: Any, see assembly recommendations below.
MOUNTINGS	: All standard mountings for PES cylinders (see P229-18). Centre trunnion (consult us).

ROD LOCK DEVICE

FLUID	: Air or neutral gas, filtered, lubricated or unlubricated
DISENGAGE PRESSURE	: 4 bar (min.), 8 bar (max.)
MAX. SYSTEM PRESSURE	: 10 bar
AMBIENT TEMPERATURE	: -5°C, +70°C
MOUNTING POSITION	: Optional, see following pages for assembly recommendations .

MECHANICAL CHARACTERISTICS

HOLDING FORCE (static)	Ø 40 mm : 1000 N	Ø 63 mm : 2500 N	Ø 100 mm : 6300 N
	Ø 50 mm : 1600 N	Ø 80 mm : 4000 N	

LOCKING CAPACITY : **Maximum load, in kg**, that can be stopped dynamically over a distance of 50 mm in relation to the rate of speed of the rod (the cylinder must be in a vertical mounting position).

V(mm/s)	Ø 40	Ø 50	Ø 63	Ø 80	Ø 100
500	80	130	200	320	500
200	90	145	225	360	590

MAX. ALLOWABLE SPEED	: 500 mm/s
NUMBER OF CYCLES	: 1.5×10^6 (at 20° C, at a balanced stop , in hold function, cycle = 1 Hz)

CHOICE OF EQUIPMENT

■ UNIT CONSISTING OF CYLINDER WITH TIE RODS + ROD-LOCKING DEVICE

COMMANDE

When ordering, please specify:

- CYLINDER + ROD-LOCKING DEVICE
 - The code of the **unit** consisting of the PES CYLINDER + ROD-LOCKING DEVICE
 - The code of cylinder equipped for rod-locking with stroke to specify
 - The code of rod-locking
- MOUNTINGS: The code(s) for the mountings and quantity (see P229-18) - Consult us for centre trunnion.
- DETECTORS ON CYLINDER: The codes of the magnetic position detectors which must be ordered separately:
 - "T" model (see page P291), reed switch or magneto-resistive type
 - "BIM" model, magneto-inductive (see page P297)

Ø cylinder (mm)	CODES		
	PES cylinder + rod locking device	Cylinder equipped for dynamic rod-locking device	Dynamic rod locking device
40	45055556	45050951 ⁽¹⁾	88145265
50	45055557	45050952 ⁽¹⁾	88145266
63	45055558	45050953 ⁽¹⁾	88145267
80	45055559	45050954 ⁽¹⁾	88145268
100	45055562	45052073 ⁽¹⁾	88145269

(1) Please specify stroke length (in mm)

Ordering example for a unit:

- Rod-locking device with PES cylinder with tie rods, aluminium barrel, series 450, Ø80 mm
- Code of unit = **45055559**
 - Code of cylinder, stroke 100 mm = **450509540100**
 - Code of rod-locking, Ø 80 mm = **88145268**

**UNIT CONSISTING OF CYLINDER WITH PROFILED BARREL + ROD-LOCKING DEVICE
POSITION OF THE T-SLOT AND THE DOVETAIL GROOVES**

Series 453 PES cylinders offer the advantage of being able to position the T-slot grooves on the cylinder in 4 different positions with reference to the axes of the pressure supply ports. The position must be specified when defining the cylinder code.

STANDARD POSITION OF THE T-SLOT GROOVES

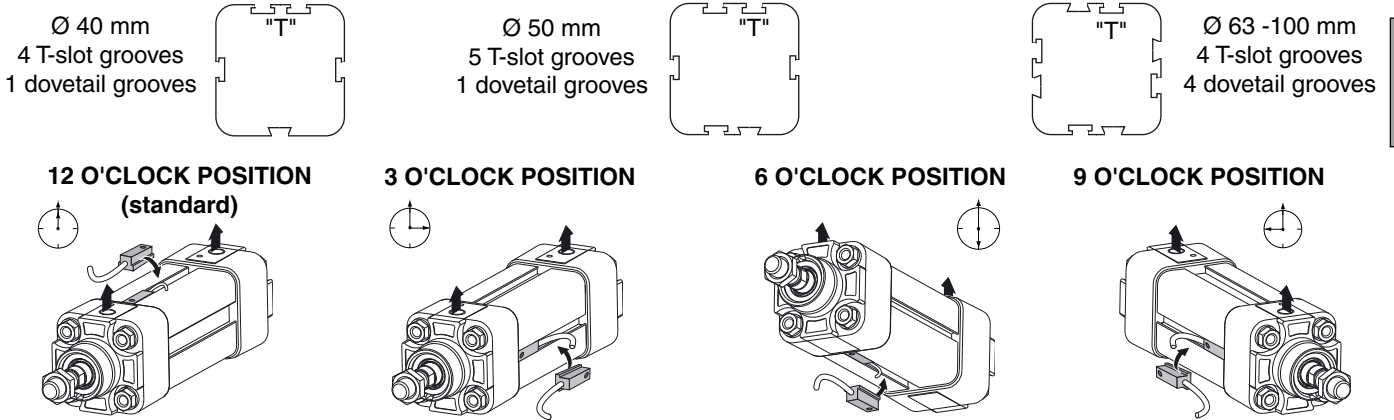

CHOICE OF EQUIPMENT

When ordering, please specify:

- LE CODE OF THE UNIT CONSISTING OF THE PES CYLINDER + ROD LOKING DEVICE -**

Ø 40	=	45355556
Ø 50	=	45355557
Ø 63	=	45355558
Ø 80	=	45355559
Ø 100	=	45355562

CYLINDER

- The air cylinder type (profiled, with cushioning, equipped for magnetic position detection).
- The position of the T-slot groove or dovetail groove on the cylinder.
- The cylinder diameter and its stroke.

DETECTORS : The magnetic position detectors must be ordered separately:

- "T" model (see page P291), reed switch or magneto-resistive type

453 5

CYLINDER TYPE			Type
Barrel	Cushioning	Position detection	
Profiled barrel	Cushioned	Equipped	0U

Ø Bore (mm)	Standard strokes (mm) (1)										
	(recommended standard strokes)										
	50	80	100	125	160	200	250	320	400	500	600
40	●	●	●	●	●	●	●	●	●	●	●
50-63	●	●	●	●	●	●	●	●	●	●	●
80-100	●	●	●	●	●	●	●	●	●	●	●

(1) Other strokes on request.

GROOVE POSITION		Type
Position of the T-slot grooves on the profiled PES cylinder	12 o'clock	0
	3 o'clock	3
	6 o'clock	6
	9 o'clock	9
Position of the dovetail grooves on the profiled PES cylinder	12 o'clock	9
	3 o'clock	0
	6 o'clock	3
	9 o'clock	6

Ø CYLINDER	
Type	Ø bore (mm)
4	40
5	50
6	63
8	80
1	100

Ordering example

- profiled cylinder with pneumatic cushioning equipped for detectors = **0U**
- T-slot grooves at 3 o'clock position = **3**
- Cylinder Ø 80 mm = **8**
- Stroke 100 mm = **0100**

Ordering example for a unit :

Code of unit = **45055559**
 Code of cylinder = **45350U380100**
 Code of rod-locking, Ø 80 mm = **88145268**

- THE CODE OF ROD-LOCKING DEVICE -**

Ø 40	=	88145265
Ø 50	=	88145266
Ø 63	=	88145267
Ø 80	=	88145268
Ø 100	=	88145269

ACCESSORIES : Protective groove cover and detector cable holder - see leaflet P291

MOUNTINGS : see page P229-18

HORIZONTAL MOUNTING

The cylinder is controlled by a 5/3 valve (ISO size 1 for diameters 40 and 50 mm, ISO size 2 for diameters 63, 80 and 100 mm), with centre open to the central port (type W2 - fig.1), or centre open to exhaust (type W3 - fig.2), and supplied by exhaust ports 3 and 5. In both options, the pressure is maintained on both sides of the cylinder piston and the forces exerted on it are balanced. This prevents any accidental movement of the rod when it is disengaged. Type W2 is recommended for its simpler wiring. Do not use a 5/3 valve with closed centre (type W1), since this will unbalance the piston in case one of the components in the circuit leaks.

NOTE: The cylinder rod may move out slowly after release of the system as a result of the "rod effect".

One-directional flow reducers must be used to control the rate of speed of the rod.

The rod lock device must be activated by a 3/2 NC solenoid valve, with a minimum passage diameter of 8 mm, to ensure fast braking of the cylinder rod. Locking by absence of air.

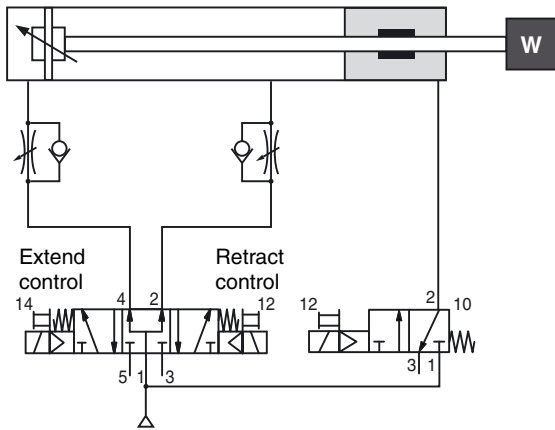

Fig. 1 - Cylinder control with a 5/3 valve, centre open on central port (type W2).

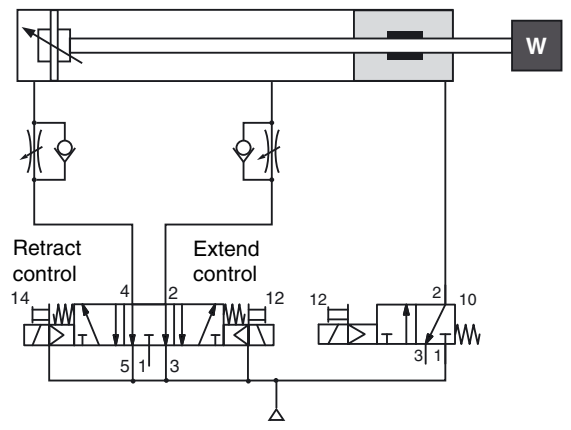

Fig. 2 - Cylinder control with a 5/3 valve, centre open to exhaust (type W3).

VERTICAL MOUNTING

The cylinder is controlled by a 5/3 valve (ISO size 1 for diameters 40 and 50 mm, ISO size 2 for diameters 63, 80 and 100 mm), with centre open to exhaust (type W3), and supplied by the exhaust ports. To ensure that the lock functions properly, the force on the piston which is generated by pressure - and which operates in the same direction as the load - must not exceed the locking capacity of the device when it is combined to the force of the load (see table on opposite page).

Do not use a 5/3 valve with closed centre (type W1) since this will unbalance the piston in case one of the components in the circuit leaks. This could be hazardous when the rod is disengaged.

Use of a 5/3 (type W3) valve provides a braking effect and ensures that the rod is held in a given position. The stopping precision depends on the rate of speed of the rod and the loads in motion.

One-directional flow reducers must be used to control the rate of speed of the rod.

The rod lock device must be activated by a 3/2 NC solenoid valve, with a minimum passage diameter of 8 mm, to ensure fast braking of the cylinder rod. Locking by absence of air.

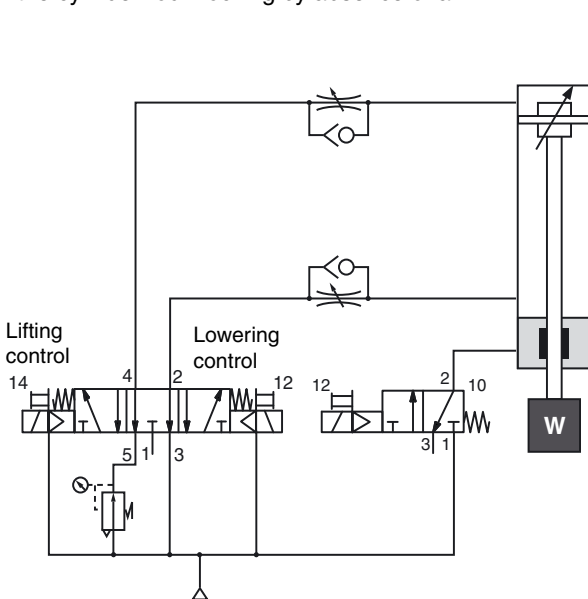

Fig. 3 - Load underneath the cylinder

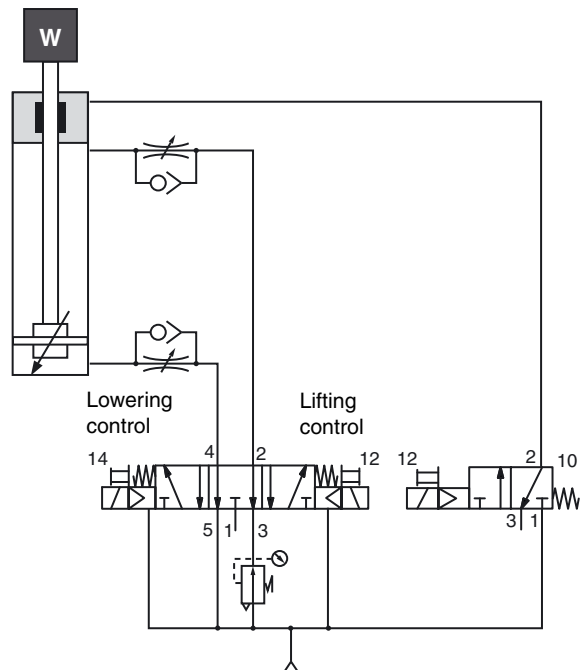

Fig. 4 - Load on top of the cylinder

MOUNTING AND OPERATING RECOMMENDATIONS

Precautions should be taken when installing a cylinder fitted with a rod-locking device. It is important to clearly define the type of layout that is required and the operating conditions of the cylinder.

The cylinder must be locked only in case of need in the event of an emergency shutdown or a situation such as:

- failure in electric supply;
- failure in pneumatic supply;
- drop in pressure.

The rod locking device can, however, be activated in every cycle as soon as the cylinder has come to a stop (hold function).

The cylinder may be fitted horizontally or vertically, with the rod either upward or downward. It may also be tilted, with the rod either upward or downward.

A specific layout corresponds to each application. The specimen layouts on the opposite page show the principles to be observed and the stops caused by interruption of the power supply or removal of the pressure by means of electropneumatic valves.

In the case of a vertical movement of the load, the force on the piston which is generated by pressure - and which operates in the same direction as the load - must not exceed the locking capacity of the device when it is combined to the force of the load (see table on preceding page).

The rate of speed of the rod must be less than 500 mm/sec.

After any emergency locking operation, make sure that the chambers of the cylinder are filled before the signal to unlock the device is given.

The rod-locking device is fitted with 2 wiper seals made of PUR. It is recommended to grease the rod lightly at regular intervals with a non-detergent class ISO VG 32 oil without aggressive additives (commonly used in pneumatic circuits). Do not let the rod come into contact with any other oils or products which might damage the wiper seals made of PUR.

It is recommended to check the correct operation of the rod-locking devices at regular intervals.

Note: Position control for rod-locking device on request : consult us.

DIMENSIONS AND WEIGHTS

- Weight of the rod-locking device alone: Ø 40 = 1.3 kg
 (Light-alloy body) Ø 50 = 1.5 kg
 Ø 63 = 3.1 kg
 Ø 80 = 3.5 kg
 Ø 100 = 5.6 kg

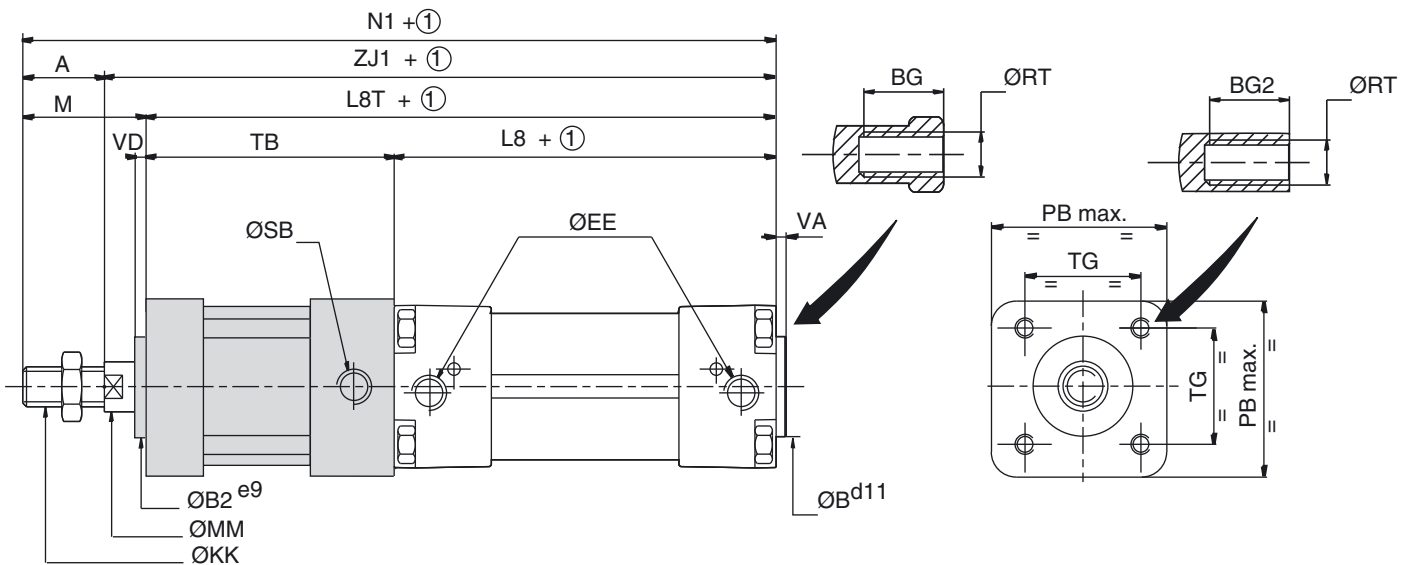

① : + stroke

Ø Cylinder (mm)	DIMENSIONS (mm)																			
	A	ØB	ØB2	BG	BG2	ØRT	ØEE	ØKK	L8	L8T	M	ØMM	N1	PB	ØSB	TB	TG	VA	VD	ZJ1
40	24	35	35	16	9	M6	G1/4	M12x1,25	105	200	54	16	254	70	G1/8	95	38	4	4	230
50	32	40	40	16	12	M8	G1/4	M16x1,5	106	218	69	20	287	75	G1/4	112	46,5	4	4	255
63	32	45	45	16	12	M8	G3/8	M16x1,5	121	241	69	20	310	95	G1/4	120	56,5	4	4	278
80	40	45	45	17	14	M10	G3/8	M20x1,5	128	268	86	25	354	95	G1/4	140	72	4	4	314
100	40	55	55	17	15	M10	G1/2	M20x1,5	138	288	91	25	379	120	G1/4	150	89	4	4	339

NOTE : The locking device is mounted in line and centered on the piston rod. Its outside dimensions are approximately equal to the standard dimensions of the cylinder. The lengths of the versions equipped with the rod-locking device correspond to the standard lengths of the cylinders (see standard products) to which dimension TB is added.

Dimensions of mountings: see P229-18.

00242GB-2011/R01
Availability, design and specifications are subject to change without notice. All rights reserved.

B