

MOUNTINGS CONFORMING WITH ISO 21287 - ISO 15552 - AFNOR NF ISO 15552 - DIN ISO 15552 STANDARDS

application	duty	standard duty											supports (2) for centre trunnion AT4
			low feet (2) MS1	high foot (1) NFE 49003-5 MS3	rectangular front or rear flange MF1 - MF2	European patent n°06 291 828.9			centre trunnion MT4		for PES with tie rods		
						for PES 453-PEC 449 with profiled barrel			for PES 453-PEC 449 with profiled barrel		for PES with tie rods		
			supplied fixed /XV (3)	supplied loose (4)	delivered only (5)	supplied fixed /XV (3)	supplied loose (4)	supplied fixed /XV (3)	supplied loose (4)	supplied fixed /XV (3)			
construction			stamped sheet steel	drawn steel	steel	steel	steel	steel	cast iron	cast iron	cast iron + bush	aluminium	
for cylinder Ø			catalogue number										
20			43400549	-	43400550	-	-	-	-	-	-	-	
25			43400553	-	43400554	-	-	-	-	-	-	-	
32			43400163	43400307	43400119	410592	410598	43400555	410564	410570	410548	43400207	
40			43400164	43400308	43400120	410593	410599	43400556	410565	410571	410549	43400208	
50			43400165	43400309	43400121	410594	410600	43400557	410566	410572	410550	43400208	
63			43400166	43400310	43400122	410595	410601	43400558	410567	410573	410551	43400209	
80			43400167	43400311	43400123	410596	410602	43400559	410568	410574	410552	43400209	
100			43400168	-	43400124	410597	410603	43400560	410569	410575	410553	43400210	
125*			43400169	-	43400192	-	-	-	-	-	410554	43400210	
160*			43400381	-	43400342	-	-	-	-	-	410555	43400341	
200*			43400382	-	43400343	-	-	-	-	-	410556	43400341	
dimensions			page 3	page 3	page 2	page 6			page 6		page 6	page 7	

* For cylinders PES serie 450

application	duty	standard duty											
			cap, detachable clevis MP2			cap, detachable eye (trunnion) MP4			angular clevis bracket AB3				
			aluminium + bush	cast iron + steel without bush	cast iron + steel + bush	aluminium without bush	aluminium + bush	light alloy	cast iron without bush	cast iron + bush	aluminium + bush	cast iron without bush	cast iron + bush
for cylinder Ø			catalogue number										
20			-	-	-	43400547	43400548	-	-	-	-	-	
25			-	-	-	43400551	43400552	-	-	-	-	-	
32			43400130	43400257	43400185	-	-	43400125	43400266	43400171	43400383	43400145	43400110
40			43400131	43400258	43400186	-	-	43400126	43400267	43400172	43400384	43400146	43400111
50			43400132	43400259	43400187	-	-	43400127	43400268	43400173	43400385	43400147	43400112
63			43400133	43400260	43400188	-	-	43400128	43400269	43400174	43400386	43400148	43400113
80			43400134	43400261	43400189	-	-	43400129	43400270	43400175	43400387	43400149	43400114
100			43400135	43400262	43400190	-	-	43400161	43400271	43400176	43400388	43400150	43400115
125*			-	43400263	43400191	-	-	-	43400272	43400177	-	43400151	43400116
160*			-	43400264	43400335	-	-	-	43400273	43400337	-	43400152	43400117
200*			-	43400265	43400336	-	-	-	43400274	43400338	-	43400153	43400118
dimensions			page 4			page 4			page 4				

* For cylinders PES serie 450

- (1) High foot sold individually
- (2) Corresponds to a set of 2 parts.
- (3) Trunnion supplied **fixed to the barrel** at dimension XV specified when ordered:
The centre trunnion code fixed and the dimension XV along with orientation code of the trunnion with respect to the ports must be added to the cylinder code.
(example: 45000020 + options 410523 / XV = 210 + 410002)
- (4) Trunnion supplied **loose** on cylinder barrel for on-site adjustment to required dimension:
The centre trunnion code loose and the dimension XV along with orientation code of the trunnion with respect to the ports must be added to the cylinder code
- (5) Only for PEC series 449

NOTE: With the exception of the centre trunnion, mountings are delivered separately.

Centre trunnion orientation

- Trunnion axis is perpendicular to supply ports, code : **410002** (standard orientation)
- other position upon request, code : **410003** (except PEC ISO Ø 32 to 50 equipped with centre trunnion MT4 type A)

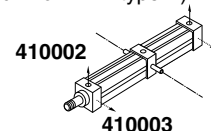

		cap clevis for spherical eye or clevis bracket AB6	cap eye with spherical eye (5) MP6	angular clevis bracket spherical bearing (5) AB5	femelle rod clevis (7) ISO 8140 - RP102P AP2	spherical rod end ISO8139-RP103P AP6	alignment compensator (6) (6)			
application duty	standard	●	●	●	●	●	●			
	heavy	●	●	●	●	●	●			
Construction		forged steel	forged steel	forged steel	steel	steel	steel			
for cylinder Ø		catalogue number								
					PES	PEC	PES	PEC	PES	PEC
20		-	-	-	-	43900161	-	43900187	-	43400561
25		-	-	-	-	43900161	-	43900187	-	43400561
32		43400363	43400372	43400354	43400016	43400016	43400001	43400001	43400242	43400242
40		43400364	43400373	43400355	43400017	43400016	43400002	43400001	43400243	43400242
50		43400365	43400374	43400356	43400018	43400017	43400003	43400002	43400244	43400243
63		43400366	43400375	43400357	43400018	43400017	43400003	43400002	43400244	43400243
80		43400367	43400376	43400358	43400019	43400018	43400004	43400003	43400245	43400244
100		43400368	43400377	43400359	43400019	43400018	43400004	43400003	43400245	43400244
125*		43400369	43400378	43400360	43400020	-	43400005	-	-	-
160*		-	-	-	43400021	-	43400006	-	-	-
200*		-	-	-	43400021	-	43400006	-	-	-
dimensions		page 5	page 5	page 5	page 7		page 7		page 8	

* For cylinders PES serie 450

(5) These accessories allows accurate angular compensation adjustment spherical of 4°

(6) This accessorie allows accurate angular compensation adjustment spherical of 4° and radial of 0,7 mm

(7) Ø125 to 200 mm: Clevis with axis locking pin

NOTE: With the exception of the centre trunnion, mountings are delivered separately.

DIMENSIONS (mm), WEIGHT (kg)

RECTANGULAR FRONT OR REAR MOUNTING FLANGE - MF1 - MF2

PES type CYLINDER

PEC type CYLINDER

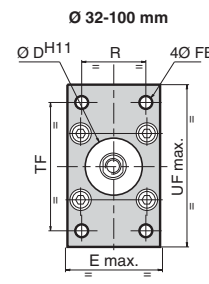
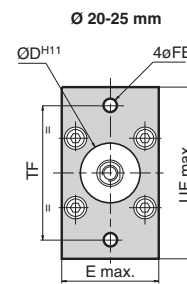
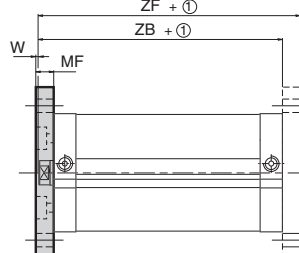
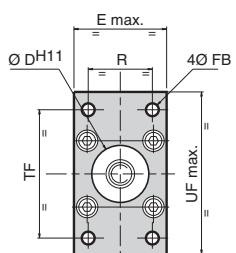
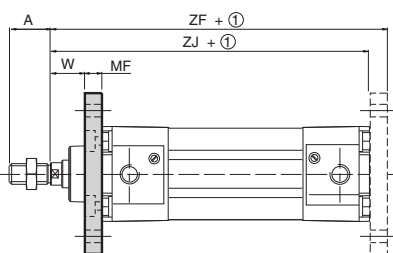

① : Stroke

Ø	PES type cylinder									PEC type cylinder			weight		
	A	ØD	E	ØFB	MF	R	TF	UF	W	ZJ	ZF	W		ZB	ZF
20	-	16	38	6,6	8	-	55	70	-	-	-	2	43	51	0,016
25	-	16	41	6,6	8	-	60	76	-	-	-	2	45	53	0,020
32	22	30	50	7	10	32	64	86	16	120	130	3	55	65	0,190
40	24	35	58	9	10	36	72	96	20	135	145	3	55	65	0,245
50	32	40	70	9	12	45	90	115	25	143	155	4	56	67	0,500
63	32	45	85	9	12	50	100	130	25	158	170	4	59,5	71,5	0,580
80	40	45	105	12	16	63	126	165	30	174	190	6	66,5	82,5	1,390
100	40	55	130	14	16	75	150	187	35	189	205	6	77,5	93,5	1,630
125	54	60	157	16	20	90	180	224	45	225	245	-	-	-	4,270
160	72	65	195	18	20	115	230	280	60	260	280	-	-	-	6,880
200	72	75	238	22	25	135	270	320	70	275	300	-	-	-	12,330

DIMENSIONS (mm), WEIGHT (kg)

LOW FEET MOUNTING - MS1

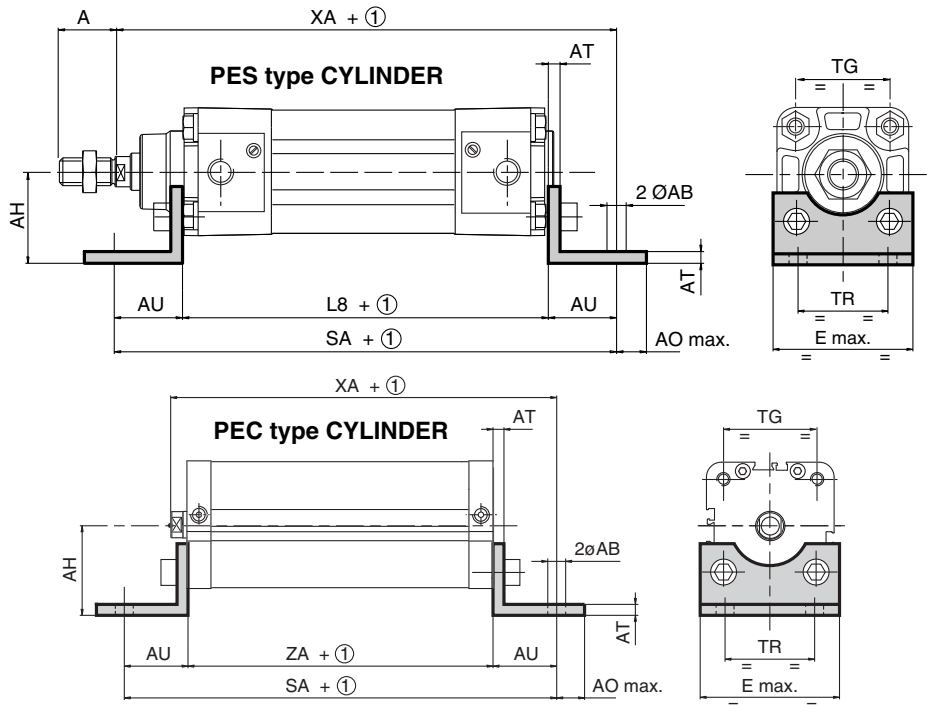

HIGH FOOT MOUNTING - MS3 (sold individually)

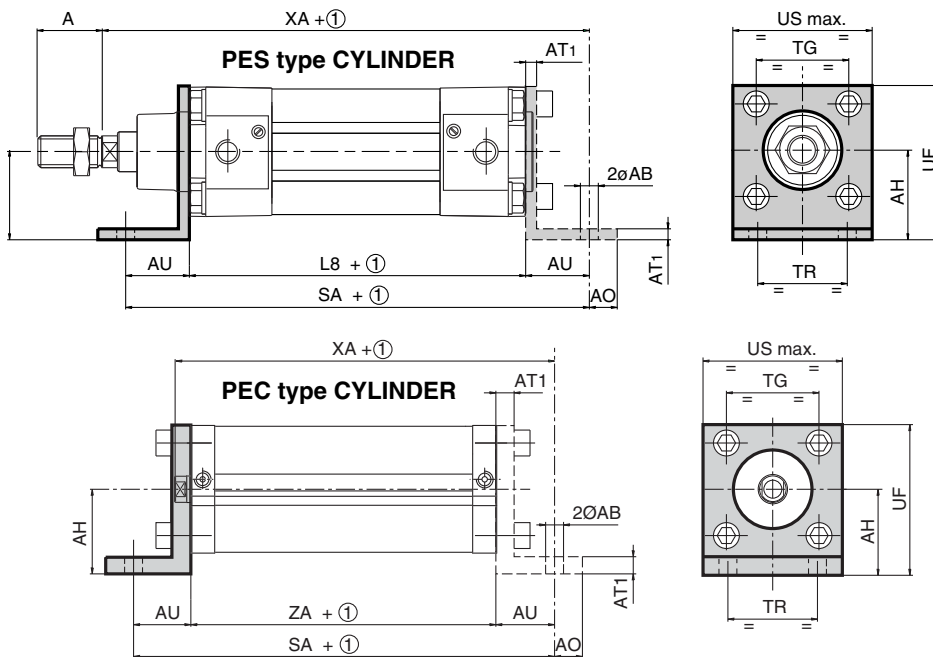

① : Stroke

Ø													PES type cylinder			PEC type cylinder			weight	
	ØAB	A	AO	AH	AT	AT1	AU	E	TR	TG	UF	US	L8	SA	XA	ZA	SA	XA	2 x MS1	1 x MS3
20	7	-	7	27	4	-	16	38	22	22	-	-	-	-	-	37	69	59	0,064	-
25	7	-	7	29	4	-	16	41	26	26	-	-	-	-	-	39	71	61	0,076	-
32	7	22	11	32	4	8	24	50	32	32,5	54	50	94	142	144	44	92	79	0,150	0,180
40	10	24	15	36	4	8	28	58	36	38	62	58	105	161	163	45	101	83	0,190	0,250
50	10	32	15	45	5	10	32	70	45	46,5	77	70	106	170	175	45	109	88	0,395	0,470
63	10	32	15	50	5	10	32	85	50	56,5	87	85	121	185	190	49	113	91,5	0,445	0,595
80	12	40	20	63	6	12	41	105	63	72	110	105	128	210	215	54	146	107,5	0,790	1,265
100	14,5	40	25	71	6	12	41	130	75	89	130	130	138	220	230	67	149	128,5	1,400	-
125	16,5	54	25	90	8	16	45	157	90	110	161	157	160	250	270	-	-	-	2,330	-
160	18,5	72	25	115	10	-	60	195	115	140	-	-	180	300	320	-	-	-	4,860	-
200	24	72	35	135	12	-	70	238	135	175	-	-	180	320	345	-	-	-	7,900	-

00218GB-2007/R01
Availability, design and specifications are subject to change without notice. All rights reserved.

B

DIMENSIONS (mm), WEIGHT (kg)

CAP, DETACHABLE CLEVIS MOUNTING - MP2

Bore Ø	32	40	50	63	80	100	125	160	200
	Weight								
Light alloy	0,105	0,150	0,240	0,370	0,635	0,990	-	-	-
Cast iron+steel	0,205	0,305	0,430	0,685	1,375	2,100	3,570	6,660	9,890

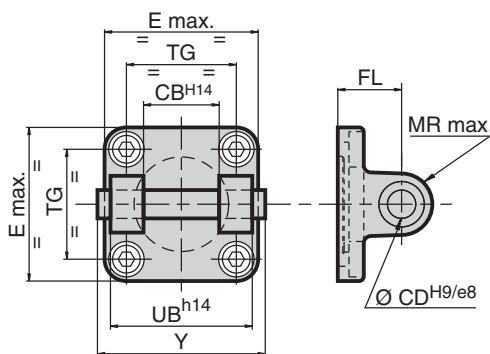

CAP, DETACHABLE EYE (TRUNNION) MOUNTING - MP4

Bore Ø	20	25	32	40	50	63	80	100	125	160	200
	weight										
Aluminium	0,021	0,027	-	-	-	-	-	-	-	-	-
Light alloy	-	-	0,085	0,092	0,170	0,250	0,445	0,755	-	-	-
Cast iron+steel	-	-	0,210	0,230	0,430	0,620	1,110	1,700	3,100	5,220	7,780

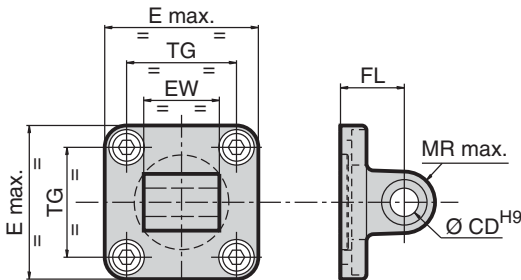

STRAIGHT COMPLETE TRUNNION MOUNTING WITH OR WITHOUT BUSH - MP2 + MP4

To achieve the complete assembly, items MP2 and MP4 must be ordered separately.

Bore Ø	32	40	50	63	80	100	125	160	200
	weight								
Light alloy	0,190	0,240	0,410	0,620	1,080	1,745	-	-	-
Cast iron+steel	0,415	0,535	0,860	1,305	2,485	3,800	6,670	11,880	17,670

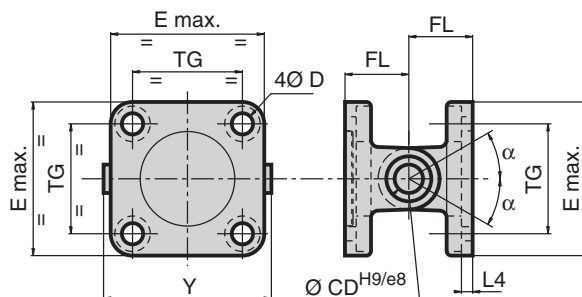

COMPLETE TRUNNION MOUNTING WITH ANGULAR CLEVIS BRACKET - WITH OR WITHOUT BUSH - MP2 + AB3

This set includes the cap, detachable clevis MP2 and the angular clevis bracket AB3, with or without bush.

These mountings must be ordered separately

Bore Ø	32	40	50	63	80	100	125	160	200
	weight								
Light alloy	0,160	0,230	0,390	0,570	0,950	1,500	-	-	-
Cast iron+steel	0,340	0,450	0,790	1,080	2,090	2,750	6,610	12,470	16,760

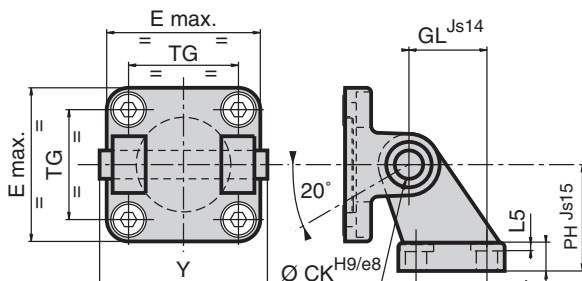

PES CYLINDER

XD + ①

PEC CYLINDER

XD + ①

① : Stroke

Bore Ø	20	25	32	40	50	63	80	100	125	160	200
A	-	-	22	24	32	32	40	40	54	72	72
XD (PES cyl.)	-	-	142	160	170	190	210	230	275	315	335
XD (PEC cyl.)	63	65	73	77	80	89	100	118	-	-	-

Ø	BT	CB	ØCD ØCK	ØD	E	EM	EW	FL	GL	ØHB	L4	L5	MR	PH	RA	TE	TG	UB	UL	UR	Y	α
20	-	-	8	-	38	-	16	20	-	-	-	-	9	-	-	-	22	-	-	-	-	-
25	-	-	8	-	41	-	16	20	-	-	-	-	9	-	-	-	26	-	-	-	-	-
32	8	26	10	6,6	50	26	26	22	21	6,6	5,5	1,6	11	32	18	38	32,5	45	51	31	56	45°
40	10	28	12	6,6	58	28	28	25	24	6,6	5,5	1,6	13	36	22	41	38	52	54	35	63	50°
50	12	32	12	9	70	32	32	27	33	9	6,5	1,6	13	45	30	50	46,5	60	65	45	71	40°
63	12	40	16	9	85	40	40	32	37	9	6,5	1,6	17	50	35	52	56,5	70	67	50	81	55°
80	14	50	16	11	105	50	50	36	47	11	10	2,5	17	63	40	66	72	90	86	60	101	45°
100	15	60	20	11	130	60	60	41	55	11	10	2,5	21	71	50	76	89	110	96	70	128	35°
125	20	70	25	14	157	70	70	50	70	14	10	3,2	26	90	60	94	110	130	124	90	149	30°
160	25	90	30	14	195	90	90	55	97	14	10	4	31	115	88	118	140	170	156	126	183	30°
200	30	90	30	18	238	90	90	60	105	18	11	4	31	135	90	122	175	170	162	130	183	30°

DIMENSIONS (mm), WEIGHT (kg)

CAP, DETACHABLE CLEVIS MOUNTING - FOR SPHERICAL EYE (STRAIGHT) OR ANGULAR CLEVIS BRACKET - AB6

Bore Ø	32	40	50	63	80	100	125	160	200
	weight								
Forged steel	0,190	0,300	0,460	0,680	1,460	2,130	4,240	-	-

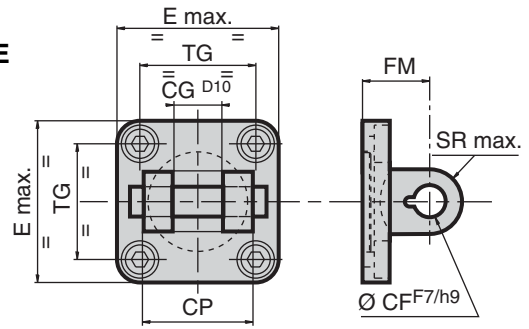

CAP, DETACHABLE EYE MOUNTING WITH SPHERICAL BEARING - MP6

Bore Ø	32	40	50	63	80	100	125	160	200
	weight								
Forged steel	0,180	0,290	0,420	0,650	1,210	1,870	3,640	-	-

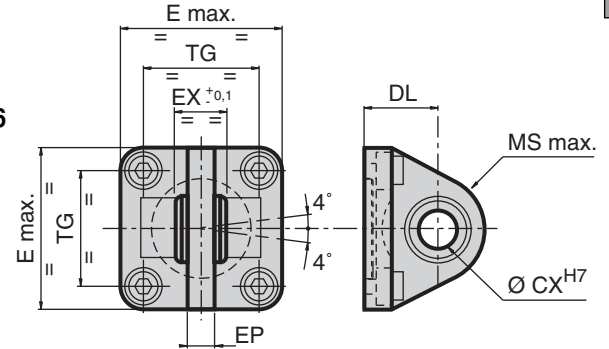

STRAIGHT COMPLETE TRUNNION MOUNTING, SPHERICAL BEARING

This set includes the cap AB6, clevis for spherical eye and the cap, eye with spherical bearing MP6.

These mountings must be ordered **separately**

Bore Ø	32	40	50	63	80	100	125	160	200
	weight								
Forged steel	0,370	0,590	0,880	1,330	2,670	4,000	7,880	-	-

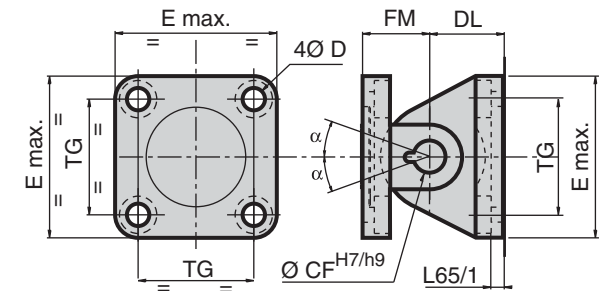

COMPLETE TRUNNION MOUNTING WITH ANGULAR CLEVIS BRACKET - SPHERICAL BEARING

This set includes the cap AB6, detachable eye and the angular clevis bracket spherical eye AB5.

These mountings must be ordered **separately**

Bore Ø	32	40	50	63	80	100	125	160	200
	weight								
Forged steel	0,370	0,530	0,910	1,200	2,400	3,200	6,710	-	-

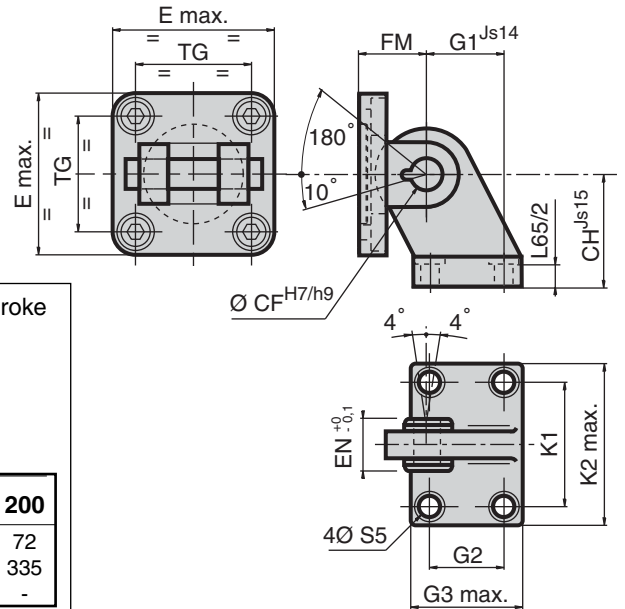

PES CYLINDER

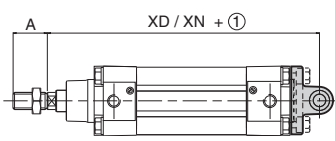

PEC CYLINDER

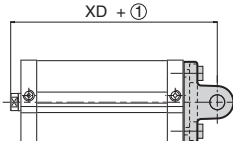

① : Stroke

Bore Ø	32	40	50	63	80	100	125	160	200
A	22	24	32	32	40	40	54	72	72
XD/XN (PES cyl.)	142	160	170	190	210	230	275	315	335
XD (PES cyl.)	73	77	80	89	100	118	-	-	-

Ø	CG	CH	CP	ØCX ØCF	DL FM	E	EN EX	EP	G1	G2	G3	K1	K2	L65/1	L65/2	MS	TG	SR	Ø S5	α
32	14	32	34	10	22	50	14	10,5	21	18	31	38	51	5,5	8,5	15	32,5	11	6,6	40°
40	16	36	40	12	25	58	16	12	24	22	35	41	54	5,5	8,5	18	38	13	6,6	45°
50	21	45	45	16	27	70	21	15	33	30	45	50	65	6,5	10	20	46,5	18	9	35°
63	21	50	51	16	32	85	21	15	37	35	50	52	67	6,5	10	23	56,5	18	9	50°
80	25	63	65	20	36	105	25	18	47	40	60	66	86	10	11,5	27	72	22	11	40°
100	25	71	75	20	41	130	25	18	55	50	70	76	96	10	12,5	30	89	22	11	30°
125	37	90	97	30	50	157	37	25	70	60	90	94	124	10	16,5	40	110	30	14	25°
160	-	-	-	-	-	-	-	-	-	-	-	-	-	-	-	-	-	-	-	-
200	-	-	-	-	-	-	-	-	-	-	-	-	-	-	-	-	-	-	-	-

00218GB-2007/R01 Availability, design and specifications are subject to change without notice. All rights reserved.

B

CENTRE TRUNNION MOUNTING MT4 FOR PES 450

MT4 type C

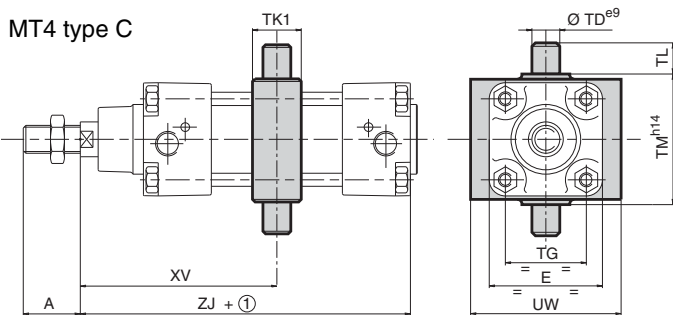

Dimension XV is specified on order

PES 450								
Ø	WITHOUT DETECTORS		WITH "UNI" DETECTORS			WITH COMPACT DETECTORS		
	XV min.	XV max.	XV min.	XV max.	① min.	XV min.	XV max.	① min.
32	72	74,5 +①	100	46,5 +①	53,5	107	39,5 +①	67,5
40	83	82,2 +①	112	53,2 +①	58,8	119	46,2 +①	72,8
50	89,5	91,3 +①	119,5	61,3 +①	58,2	126,5	54,3 +①	72,2
63	93,5	102,6 +①	130,5	65,6 +①	64,9	136,5	59,6 +①	76,9
80	106,5	114,7 +①	143,5	77,7 +①	65,8	149,5	71,7 +①	77,8
100	114	126,5 +①	156	84,5 +①	71,5	161	79,5 +①	81,5
125	135	155,5 +①	180	110,5 +①	69,5	187	103,5 +①	83,5
160	159,5	181 +①	223,5	149 +①	74,5	229,5	139 +①	90,5
200	173,5	197 +①	240,5	165 +①	75,5	247,5	155 +①	92,5

CENTRE TRUNNION MOUNTING MT4 FOR PES 453

MT4 type B

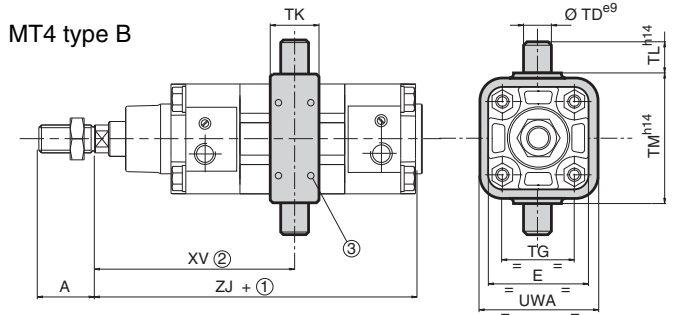

PES 453								
Ø	WITHOUT DETECTORS		WITH "T" DETECTORS			WITH COMPACT DETECTORS		
	XV min.	XV max.	XV min.	XV max.	① min.	XV min.	XV max.	① min.
32	71,5	74,5 +①	114	32,5 +①	82,5	101,5	44,5 +①	58,5
40	80,5	84 +①	123	42 +①	82	111,5	53 +①	60
50	87	93 +①	129	51 +①	79	120	60 +①	61
63	90,5	105 +①	132,5	63 +①	70	119,5	76 +①	46
80	103,5	117 +①	145,5	75 +①	71	133,5	87 +①	47
100	111	129 +①	154	86 +①	68,5	142	96 +①	44,5

MT4 type A

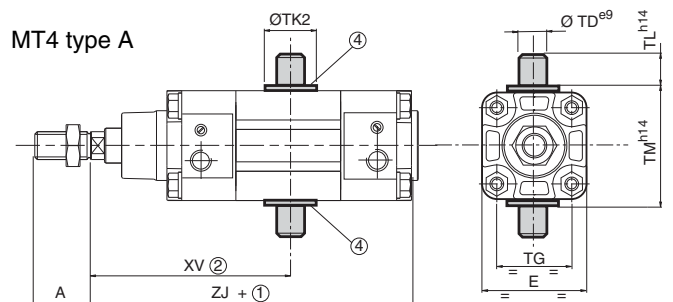

Dimension XV is specified on order

PES 453								
Ø	WITHOUT DETECTORS		WITH "T" DETECTORS			WITH COMPACT DETECTORS		
	XV min.	XV max.	XV min.	XV max.	① min.	XV min.	XV max.	① min.
32	73	73 +①	73	73 +①	74	73	73 +①	54,5
40	82,5	82 +①	82,5	82,5 +①	74	82,5	82 +①	56
50	91	89 +①	91	89,5 +①	73,5	91	89,5 +①	57
63	95,5	100 +①	95,5	100 +①	73	95,5	100 +①	35
80	108,5	112 +①	108,5	112 +①	76	108,5	112 +①	36
100	118,5	121 +①	118,5	121 +①	82,5	119	121,5 +①	40,5

CENTRE TRUNNION MOUNTING MT4 FOR PEC 449

MT4 type B

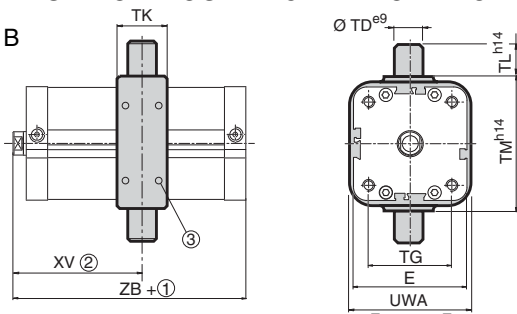

PEC 449					
Ø	WITHOUT DETECTORS		WITH COMPACT DETECTORS		
	XV min.	XV max.	XV min.	XV max.	① min.
32	33	25 +①	47	10,5 +①	37
40	34	25 +①	48	10,5 +①	38
50	35	26 +①	62	-3 +①	68
63	37	28 +①	62	3 +①	60
80	41,5	32 +①	66,5	7 +①	60
100	47	40 +①	72	15 +①	57,5

MT4 type A

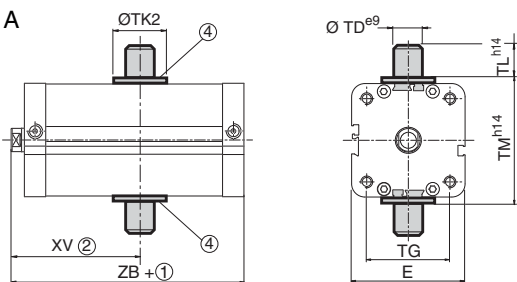

PEC 449					
Ø	WITHOUT DETECTORS		WITH COMPACT DETECTORS		
	XV min.	XV max.	XV min.	XV max.	① min.
32	34	23,5 +①	34	23,5 +①	31
40	35,5	23 +①	35,5	23 +①	34
50	38,5	22 +①	38,5	22 +①	48
63	42	23 +①	42	23 +①	36
80	46,5	27,5 +①	46,5	27 +①	33
100	54,5	32,5 +①	54,5	32,5 +①	34

Dimension XV is specified on order

- ① : Stroke
- ② : Except when dimension XV is specified on order. the position of the trunnion may be adjusted along the unit. Consequently, the centre trunnion is not screwed on and must be adjusted after delivery.
- ③ : 8 locking screws
- ④ : Mounting of the centre trunnion by pin (option)

All leaflets are available on: www.asconumatics.eu

DIMENSIONS (mm), WEIGHT (kg)

SUPPORTS FOR CENTRE TRUNNION - AT4

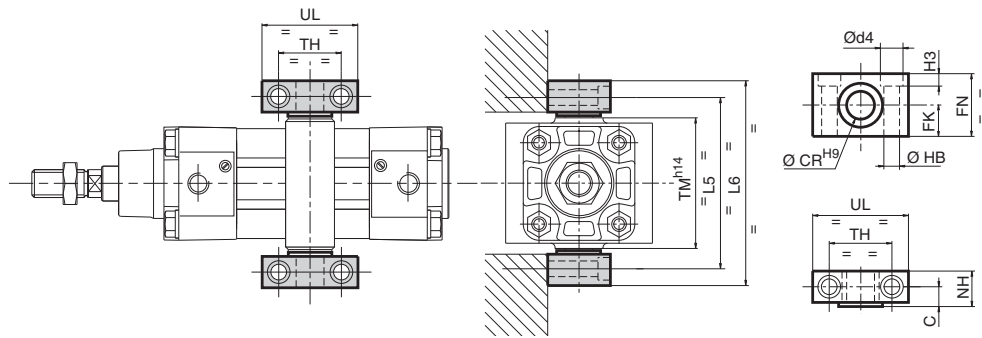

B

Ø	A	C	CR	Ød4	FK	FN	HB	H3	L5	L6	NH	TG	TH	TK	TK1	TK2	TD	TL	TM	UL	UW	UWA	ZJ
32	22	10,5	12	11	15	30	6,6	6,8	71	86	18	32,5	32	18	22	21	12	50	46	55	64,5	120	
40	24	12	16	15	18	36	9	9	87	105	21	38	36	20	28	24	16	63	55	58	74,5	135	
50	32	12	16	15	18	36	9	9	99	117	21	46,5	36	20	28	28	16	75	55	68	91	143	
63	32	13	20	18	20	40	11	11	116	136	23	56,5	42	25	35	35	20	90	65	84	94	158	
80	40	13	20	18	20	40	11	11	136	156	23	72	42	25	35	35	20	110	65	102	130	174	
100	40	16	25	20	25	50	13,5	13	164	189	28,5	89	50	30	40	45	25	132	75	145	145	189	
125	54	16	25	20	25	50	13,5	13	192	217	28,5	110	50	40	40	-	25	160	75	175	175	225	
160	72	22,5	32	26	30	60	17,5	17,5	245	280	40	140	60	50	50	-	32	200	92	220	220	260	
200	72	22,5	32	26	30	60	17,5	17,5	295	330	40	175	60	50	50	-	32	250	92	260	260	275	

Ø	weight Centre trunnion			Supports
	MT4 for PES 450	MT4 monobloc for 453-449	MT4 with flanges for 453-449	
32	0,200	0,185	0,035	0,120
40	0,400	0,330	0,083	0,230
50	0,500	0,475	0,104	0,230
63	0,900	0,570	0,210	0,330
80	1,100	1,120	0,225	0,330

Ø	weight Centre trunnion			Supports
	MT4 for PES 450	MT4 monobloc for 453-449	MT4 with flanges for 453-449	
100	1,860	1,520	0,420	0,580
125	2,550	-	-	0,580
160	4,170	-	-	1,030
200	4,200	-	-	1,030

FEMALE CLEVIS - AP2
ISO 8140 - RP 102 P

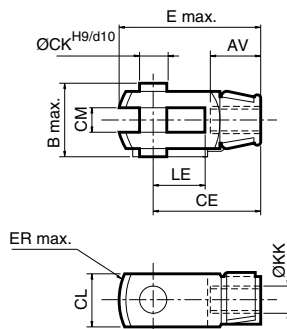

SPHERICAL BEARING ROD END - AP6
ISO 8139 - RP 103 P

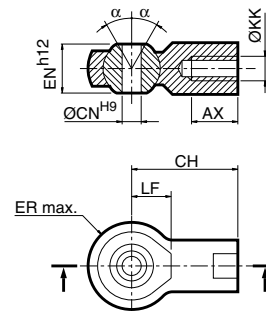

α: spherical angular compensation 4°

Ø cylinders																weight	
PES	PEC	AV-AX	B	CE	CH	ØCK	CL	CM	ØCN	E	EN	ER	ØKK	LE	LF	AP2	AP6
	20-25	15	22	32	36	8	16	8 ^{+0.5} / _{+0.15}	8	45	12	-	M8x1,25	16	13	0,050	0,050
32	32-40	20	26	40	43	10	20	10 ^{+0.5} / _{+0.15}	10	56	14	14	M10x1,25	20	15	0,100	0,070
40	50-63	22	32	48	50	12	24	12 ^{+0.5} / _{+0.15}	12	67	16	16	M12x1,25	24	17	0,150	0,120
50	80	28	41	64	64	16	32	16 ^{+0.5} / _{+0.15}	16	89	21	21	M16x1,5	32	22	0,330	0,220
63	100	28	41	64	64	16	32	16 ^{+0.5} / _{+0.15}	16	89	21	21	M16x1,5	32	22	0,330	0,220
80		33	48	80	77	20	40	20 ^{+0.6} / _{+0.15}	20	112	25	25	M20x1,5	40	26	0,670	0,390
100		33	48	80	77	20	40	20 ^{+0.6} / _{+0.15}	20	112	25	25	M20x1,5	40	26	0,670	0,390
125		51	65	110	110	30	55	30 ^{+0.6} / _{+0.15}	30	155	37	35	M27x2	54	36	1,810	1,600
160		56	84	144	125	35	70	35 ^{+0.6} / _{+0.15}	35	201	43	40	M36x2	72	41	3,850	1,600
200		56	84	144	125	35	70	35 ^{+0.6} / _{+0.15}	35	201	43	40	M36x2	72	41	3,850	1,600

00218GB-2007/R01
Availability, design and specifications are subject to change without notice. All rights reserved.

DIMENSIONS (mm), WEIGHT (kg) 

ALIGNMENT COMPENSATOR

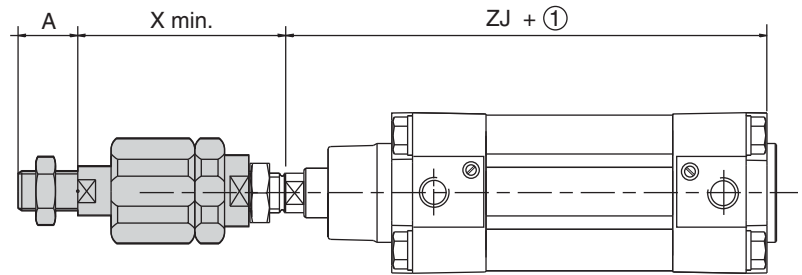
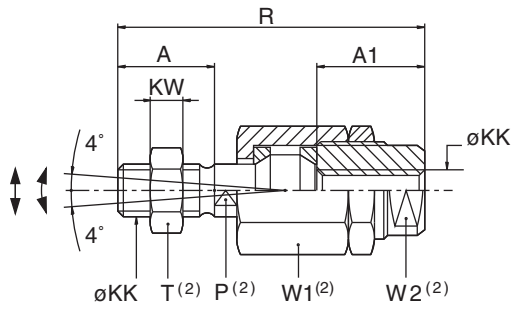

① : stroke

(2) : dimensions on flats

Ø cylinders PES	PEC	A	A1	P(2)	ØKK	KW	R	T(2)	W1(2)	W2(2)	X	radial compensation (mm)	weight
	20-25	16	18	7	M8x1,25	4	55	13	17	10	45	0,5	0,055
32	32-40	22	26	12	M10x1,25	6	73	17	30	19	58	0,7	0,210
40	50-63	24	26	12	M12x1,25	7	77	19	30	19	59	0,7	0,210
50	80	32	34	19	M16x1,5	8	106	24	42	30	82	1	0,650
63	100	32	34	19	M16x1,5	8	106	24	42	30	82	1	0,650
80		40	42	19	M20x1,5	9	122	30	42	30	92	1	0,680
100		40	42	19	M20x1,5	9	122	30	42	30	92	1	0,680
125		54	40	24	M27x2	13,5	147	41	Ø62	54	107	1	1,700

• Radial compensation: 0,5 to 1 mm (see table)

• Spherical angular: compensation : 4°

Note: The compensator is preset with an axial clearance of 0,05 to 0,1 - Do not reset.