

FEATURES

- This electronic timer, which generates adjustable pulses, is particularly suited for automatic control of draining of an air dryer or compressor as, when energised, it can initiate operation of the solenoid valve for the time necessary for draining condensates at regular adjustable intervals
- Other applications include irrigation, air blasting etc.
- Fits directly to any solenoid valve with standardised ISO 4400 / DIN connection, between coil and power connector

GENERAL / OPERATION

Converts a continuous power input into a succession of on-periods (ON), adjustable between 2 to 40 seconds and off-periods (OFF), adjustable between 0,5 to 45 minutes.

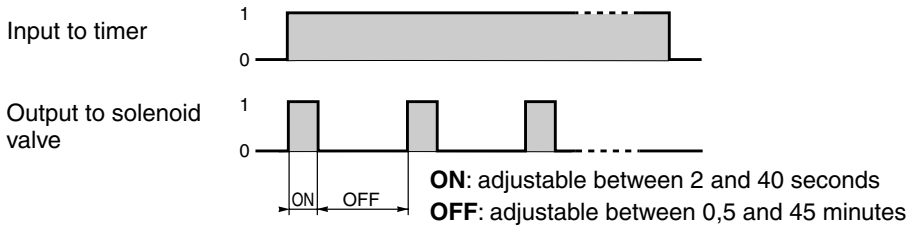

CONSTRUCTION

- Housing (1)** PA (polyamide)
- Electrical connection** 2 pins + earth to ISO 4400 for use with a connector to ISO 4400/EN 175301-803, form A (connector not supplied)
- Agreement** CSA

ELECTRICAL CHARACTERISTICS

- Standard voltages** 24 V to 240 V DC or AC (50/60 Hz)
- Max. inrush current** 10 A during 10 ms
- Consumption** 4 mA max.
- Repeatability** ± 0,1%
- Scale accuracy** ± 10%

electrical connection	maximum power (I max. = 1A)	ambient temperature range	protection degree
ISO 4400	24 VA (with 24 V) to 240 VA (with 240 V)	- 10°C to + 50°C	IP65

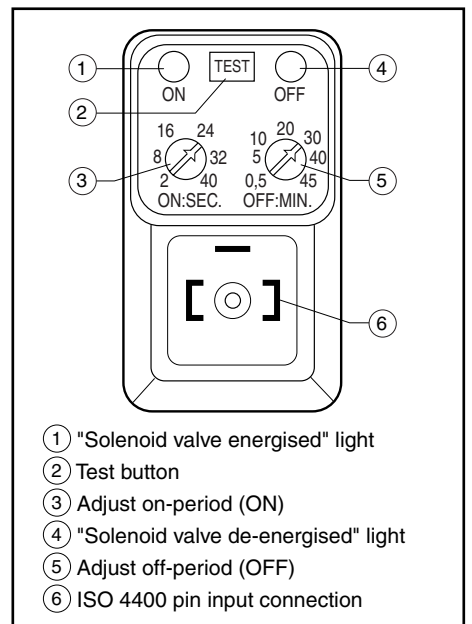

SPECIFICATIONS

description	catalogue number
Electronic timer with auxiliary manual control for solenoid valve with ISO 4400 pin coil	88122627

(1) The pin arrangement of the timer enables rotation by increments of 180°C in relation to the solenoid valve to which it is connected.

INSTALLATION

- If the width of the solenoid valve permits, the timer can be rotated about the connection axis by 180° increments
- Take care to fit properly the coil/timer seal and the connector seal
- Observe maximum power rating
- ISO 4400/EN 175301-803, form A, connection

DIMENSIONS (mm), WEIGHT (kg)

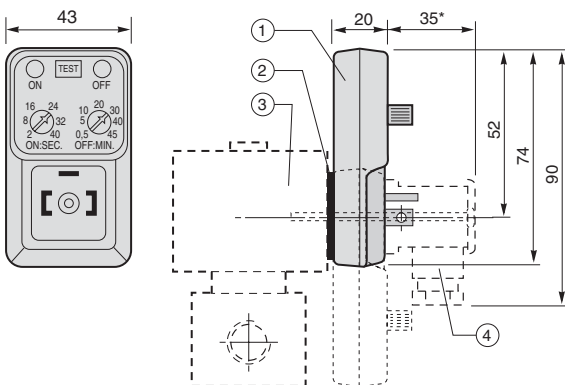

- ① Timer rotatable by 180° increments
- ② Seal
- ③ Solenoid valve with ISO 4400 standardised pin coil
- ④ ISO 4400 connector, Pg 11P, rotatable by 90° increments (not supplied)

* +15 mm pour déplacement du connecteur

Weight: 0,054 (without connector)

00146GB-2005/R02 Availability, design and specifications are subject to change without notice. All rights reserved.