

FEATURES

- Differential-action valve for high-pressure fluid control at reduced piloting pressure
- Heavy-duty valve recommended for demanding applications
- Available with several accessories and options to handle the majority of industrial applications
- The valves satisfy the Pressure Equipment Directive 97/23/EC, risk category 1 (DN 32 to 100) or article 3.3 (DN ≤ 25)

GENERAL

fluids (*)	temperature range	disc seal (*)
DN ≤ 50: air and gas groups 1 & 2 DN > 50: air and gas group 2 all DN: water (**), oil, liquids groups 1 & 2	- 10°C to + 180°C	PTFE

(**) Water 95°C max. - Do not use with steam or superheated water.

Differential pressure	0 to 16 bar [1 bar = 100 kPa]
Maximum allowable pressure	16 bar ⁽¹⁾
Ambient temperature range	-5°C to +60°C
Maximum viscosity	5000 cSt (mm ² /s)
Response time	See overleaf
Pilot fluid	Water, air, filtered
Max. pilot pressure	10 bar
Min. pilot pressure	See graphs (lower pressure: see Options)

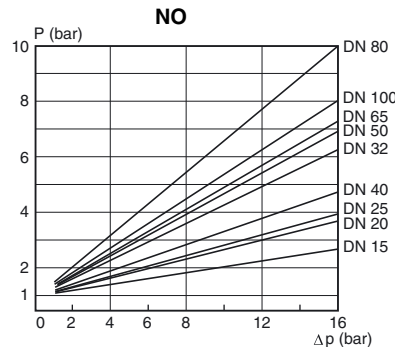
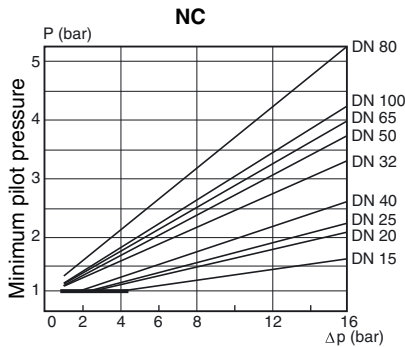

CONSTRUCTION

Connection	Flange type 21 (ISO 7005) - PN 16
Face to face dimensions	NF EN 13789 - DIN 3202 - F1
Facing	Type A
Pilot connection	G 1/4

MATERIALS IN CONTACT WITH FLUID

(*) Ensure that the compatibility of the fluids in contact with the materials is verified

Valve body	Cast iron
Stem, disc, seat	Stainless steel
Stuffing-box seal	Braided PTFE
Disc seal	PTFE
Valve body seal	Stainless steel graphite
Plug body	Cast iron or steel

OTHER MATERIALS

Diaphragm (operator)	NBR
Bonnet (operator)	Steel

SPECIFICATIONS

DN	flow coefficient Kv		maximum allowable pressure ⁽¹⁾ (bar)	pilot pressure (bar)		NC normally closed		NO normally open	
	(m ³ /h)	(l/min)		min.	max.	catalogue number	reference	catalogue number	reference
15	4,5	75	16	*	10	16500029	2503-BF	16500040	2503-BF-NO
20	7,2	120	16	*	10	16500030	2504-BF	16500041	2504-BF-NO
25	12	200	16	*	10	16500031	2505-BF	16500042	2505-BF-NO
32	18	300	16	*	10	16500032	2506-BF	16500043	2506-BF-NO
40	31,8	530	16	*	10	16500033	2507-BF	16500044	2507-BF-NO
50	39	650	16	*	10	16500034	2508-BF	16500045	2508-BF-NO
65	76,8	1280	16	*	10	16500035	2510-BF	16500046	2510-BF-NO
80	99	1650	16	*	10	16500036	2511-BF	16500047	2511-BF-NO
100	150	2500	16	*	10	16500037	2513-BF	16500048	2513-BF-NO

* The minimum pilot pressure varies according to the differential pressure across the valve. See pilot graphs above.

⁽¹⁾ The maximum allowable pressure is 16 bar for a maximum temperature of 120°C. Above this temperature, refer to standard NF EN 1092-2.

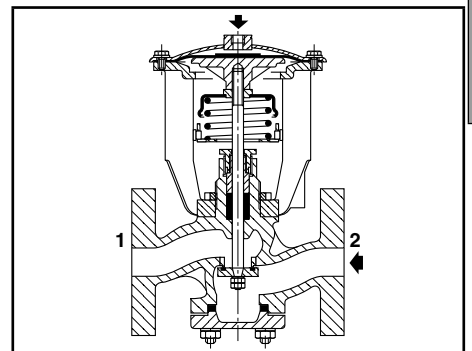

NC function

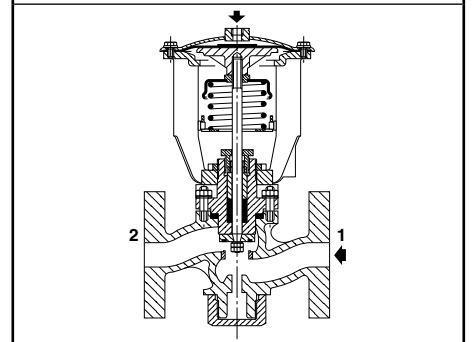

NO function

D

OPTIONS AND ACCESSORIES

- Guard mounted on valves, DN 15-20: catalogue number **210555** / DN 25-32: catalogue number **210556** / DN 40-50: catalogue number **210557** / DN 65-80: catalogue number **210558** / DN 100: catalogue number **210559** /
- Valves to ATEX 94/9/EC: for category 2, DN 15 to 100 (II 2 GD c T6 T85°C)
for category 3, DN 15 to 100 (II 3 GD c T6 T85°C X)
- Dry IP66 contacts
- 2 explosionproof switches with contacts for potentially explosive atmospheres to ATEX:

switch ambient temperature range	number of contacts	DN 15..32	DN 40..80	DN 100
-20°C to +80°C	1	260657	260658	260659
-20°C to +80°C	2	260660	260661	260662
-55°C to +82°C	1	260663	260664	260665
- Inductive M18 switch, IP66
- Inductive M18 switch, intrinsically safe to ATEX, II 1 GD EEx ia IIC T6 IP66 T85°C
- Manual override on the bonnet of the operator
- Accessories for adjustable response time (flow control, quick exhaust etc.)
- Anti-waterhammer device available with air-oil exchanger
- Backpressure applications possible by off-setting the yoke and using a reinforced spring
- Low pressure control (min. 1 bar) by off-setting the yoke (except dia. 125 and 150 valves)
- Profiled valve disc
- Other types of stuffing-boxes are available depending on the nature of the fluid used
- Modifications for special environments (cold, hot, aggressive, marine etc.)
- Other standardised flange forms
- Oxygen service, catalogue number **970509** (except DN 65 to DN 100), pressure/temperature limited to 15 bar / + 60°C
- Valve body degreased during assembly, catalogue number **970523**

INSTALLATION

- The valves can be mounted in any position, except with the operator downwards
- Be sure to observe the direction of fluid flow (NC from 2 to 1 ; NO from 1 to 2)
- Pipe connection (G) has standard thread according to ISO 228/1

SPARE PARTS KIT & ACCESSORIES

DN	spare parts kit no.				guard catalogue number
	stem and disc unit		stuffing-box unit	NBR diaphragm	
	NC	NO			
15	97701367	97701388	97701366	97700017	88200035
20	97701369	97701389	97701368	97700017	88200035
25	97701371	97701390	97701370	97700018	88200036
32	97701373	97701391	97701372	97700018	88200036
40	97701375	97701392	97701374	97700019	88200037
50	97701377	97701393	97701376	97700019	88200037
65	97701379	97701394	97701378	97700045	88200038
80	97701381	97701395	97701380	97700045	88200038
100	97701383	97701396	97701382	97700127	88200039

ORDERING EXAMPLES:

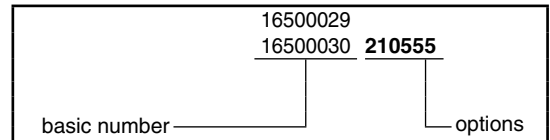

ORDERING EXAMPLES KITS:

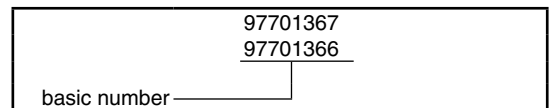

DIMENSIONS (mm), WEIGHT (kg)

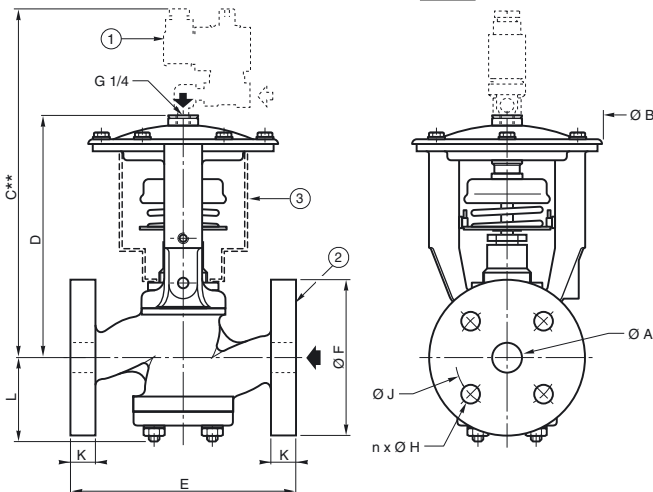

ØA (mm)	ØB	C**		D		E	ØF	n x ØH	ØJ	K	L		weight (1)
		NC	NO	NC	NO						NC	NO	
15	127	289	307	170	188	130	95	4 x Ø14	65	14	48	51	4,2
20	127	291	314	172	195	150	105	4 x Ø14	75	16	56	53	5,3
25	156	308	331	189	212	160	115	4 x Ø14	85	16	61	58	7,3
32	156	316	344	197	225	180	140	4 x Ø18	100	18	70	70	9,1
40	200	344	378	225	259	200	150	4 x Ø18	110	18	77	75	13,9
50	200	353	389	233	270	230	165	4 x Ø18	125	20	90	82,5	16,5
65	250	387	422	268	303	290	185	4 x Ø18	145	20	102	95	27
80	250	408	441	289	322	310	200	8 x Ø18	160	22	120	116	31
100	336	505	546	386	427	350	220	8 x Ø18	180	24	137	131	54

(1) Weight of valve without pilot.

** Maximum value given for reference and related to choice of electric pilot.

Response time (in sec.) for a valve with NC function

ØA (mm)	pilot fluid (6 bar)			
	air		water	
	O	C	O	C
15	0,3	1	0,7	2
20	0,3	1	0,7	2
25	0,4	1,5	1,5	4
32	0,4	1,5	1,5	4
40	0,6	2,5	3	9
50	0,6	2,5	3	9
65	0,8	4	5	15
80	0,8	4	5	15
100	1,3	7	13	37

- Solenoid pilot valves: see V480
- Flange type 21 with flat faces, type A (ISO 7005)
- Guard available as accessory, supplied separately or mounted on valve

- Response time is directly related to the Kv of the solenoid pilot valve. The time indicated at opening (O) and closing (C) of the valve is determined by a pilot (dia. 3 mm) with a Kv of 3,5.
- For an NO valve: swap the values of O and F.
- Consult us for shorter cycle times.